



Models JML-24X, JML-18X, & JML-12X

Material Lift

SERVICE MANUAL



Part Number: M-JT1-2411-SER
Edition 1 11/2025
©2025, JET
All rights reserved U.S.A.

Table of Contents



WARNING

Read and understand the safety information in this manual and in *Section 2 SAFETY INFORMATION* of the material lift Operating Instructions and Parts Manual. Failure to follow the information provided may cause serious injury or death.

1	Introduction	1
	1.1 Service Manual	1
	1.2 How To Get Technical Support	1
2	Safety Information	2
3	Product Identification	3
4	Service	4
	4.1 Cable Replacement	4
	4.1.1 Replacing Worn or Damaged Cable	4
	4.1.2 Replacing Broken Cable	5
	4.2 Cable Pulley Replacement.	10
	4.3 Winch	11
	4.3.1 Input Shaft and Outer Drive Gear Replacement.	11
	4.4 Slide Block Replacement	13

1 Introduction

1.1 SERVICE MANUAL

This manual covers common service procedures that may be needed to keep the material lift in optimum, safe operating mode. This tool is designed and constructed to provide consistent, long-term operation if used, maintained, and serviced in accordance with instructions contained in the product's operating instructions manual and in this service manual.

If you have any questions or comments, please contact either your local supplier or JET Tools. JET Tools can also be reached at our web site: www.jettools.com.

Contact the Factory:

JET Tools
427 New Sanford Road
La Vergne, TN 37086
Phone: 800.274.6848
www.jettools.com

1.2 HOW TO GET TECHNICAL SUPPORT

Please contact Technical Service by calling 1-800-274-6846. Please note that you will be asked to provide proof of initial purchase when calling. If a product requires further inspection, the Technical Service representative will explain and assist with any additional action needed. JET has Authorized Service Centers located throughout the United States. For the name of an Authorized Service Center in your area, call 1-800-274-6846 or use the Service Center locator on the JET website: www.jettools.com.

2 Safety Information

BEFORE SERVICING

1. Thoroughly read and understand the safety information in this manual and in *Section 2 SAFETY INFORMATION* of the material lift Operating Instructions and Parts Manual. Failure to follow the information provided may cause serious injury or death.
2. This material lift is designed and intended for use by properly trained and experienced personnel only. Learn how to operate this lift properly and safely. If you are not familiar with the proper and safe operation of this lift, do not use it. Follow proper and safe lifting practices.
3. Do not use this material lift for purposes other than its intended use, as outlined in the material lift Operating Instructions and Parts Manual. If used for other purposes, JET disclaims any real or implied warranty and holds itself harmless from any resulting injury or property damage.
4. Always inspect the material lift and cable for damage prior to use. If lift is damaged, repair before use. Do not attempt to lengthen or repair cables. If cable is kinked, frayed, worn, or damaged, replace before use. Replace cables with factory replacement cables only. Do not use any other type of cable.
5. Perform non-load operation tests after servicing and before each use.
6. Only use replacement parts and accessories approved and provided by JET.

SERVICE AREA SAFETY

1. Keep bystanders a safe distance from the servicing area. Keep children away. Do not allow children to access or operate this material lift.
2. Service this material lift only on solid and level surfaces that can withstand the weight of the material lift. Do not service on inclines.
3. Keep service area clear of debris and clutter.
4. This lift is not insulated from electrical current. If it contacts energized power lines, severe injury or death can occur if you are touching the lift. Keep away from the lift if it contacts energized power lines. Shut off power lines immediately and safely move the lift away from the hazard.

PERSONAL SAFETY

1. Wear proper clothing and safety gear. When servicing this material lift, wear a hard hat, safety glasses, steel-toe shoes, and gloves.
2. Always maintain your balance and firm footing when servicing the material lift.

3. Give your work undivided attention. Looking around, carrying on a conversation and “horse-play” are careless acts that can result in serious injury.
4. The material lift is heavy. Use proper lifting practices and multiple people to lift or lower the mast assembly to-or-from the horizontal transport mode or when lifting and positioning into a truck or trailer.

SERVICING SAFETY

1. Check winch for proper operation after servicing and before each use. Do not use if damaged. Repair or replace immediately.
2. Make sure cable wind/loop is in the correct orientation. The cable should always enter and exit the spool on the spool side away from the mast (not facing the mast). See Figure 2-1.
3. When operating the winch, make sure the cable winds tightly and evenly on the drum (see Figure 2.1). Do not allow the cable to bunch on one side of the drum or become crisscrossed or tangled. If this happens, wind the affected cable off the drum and re-wrap correctly.
4. Avoid sideways cable slip. When winding the cable under load, make sure a minimum space of 2-times the cable diameter remains on the drum flange.
5. Always leave at least five wraps of the cable on the drum. Failure to do so may break the cable connection to drum and result in serious injury or property damage.
6. Be aware of and avoid pinch points, such as the folding legs, mast sections, winch, cable, and lifting forks. Keep hands away from all moving parts while operating lift.
7. When raising, lowering, or moving material lift, make sure there is adequate clearance to overhead wires and other objects and/or obstructions.
8. If welding near the material lift, do not contact any part of the lift by a live electrode. Do not use this lift as a ground for welding operations. Prevent weld splatter from contacting the lift.



Figure 2-1: Cable Wrapped Tightly and Evenly

3 Product Identification

3.1 COMPONENTS



4 Service

4.1 CABLE REPLACEMENT

Cable replacement is required if the cable is worn or damaged, or if the cable breaks. The service process differs for each condition.

Replacing a worn or damaged cable is the easiest of the two procedures. Replacing the cable before a breakage occurs will result in less down-time and fewer service hours.

4.1.1 Replacing Worn or Damaged Cable

If the cable is worn or damaged, but not broken, follow the steps below. You can replace a worn or damaged cable with the mast in the vertical position.

Tools needed:

- 7/16" Wrench or Socket
- 1/2" Wrenches or Sockets
- 3/4" Wrenches or Sockets
- Electrical Tape

1. Remove the lifting fork from for carriage.
2. Position the fork carriage at the lowest position.
3. Engage the mast locking arm. To do so, pull arm outward from its position at the rear of the mast. Rotate the arm forward and release when the rubber wheel is over the fork carriage. See Figure 4-1.



Figure 4-1: Engaging Mast Locking Arm

4. Using 1/2" wrenches or sockets, remove the rear cable guard shield to access the rear mast pulley.
5. Unwind the cable from the winch reel.
6. Using 7/16" wrench or socket, loosen and remove the winch rope clamp on the winch reel (see Figure 4-2). Remove the cable from the winch reel.

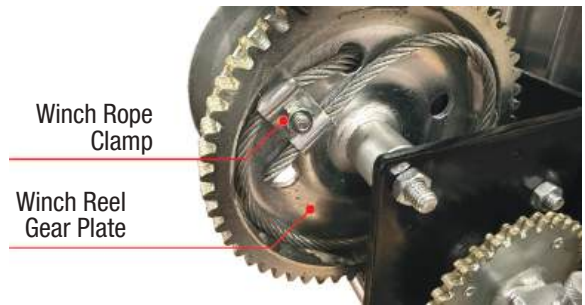

Figure 4-2: Winch Rope Clamp

7. Locate the cable eyelet at the top of the front mast (see Figure 4-3). Using two 3/4" wrenches, remove the cable eyelet retention bolt to disconnect the cable eyelet from the mast (see Figure 4-4). Save the retention bolt and hardware for re-installation.



Figure 4-3: Cable Eyelet Location

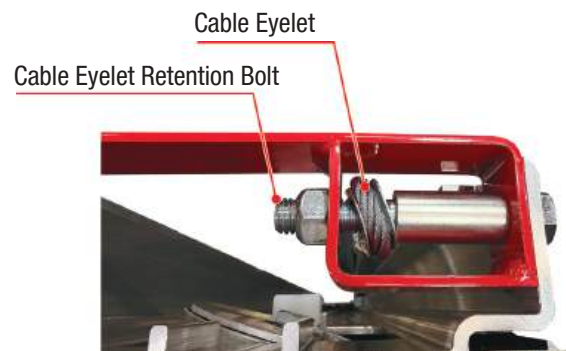

Figure 4-4: Cable Eyelet and Retention Bolt

8. Wrap the cable with electrical tape, just below the swaged portion. Using an abrasive cutoff wheel, cut through the electrical tape portion to cut the cable in two. Discard the swaged cable end.
9. Lay the cut end of the new cable to the cutoff end of the damaged cable. Make sure there is a 1/4" gap between the two cable ends. Spiral-wrap the two cables together using electrical tape (see Figure 4-5).



Figure 4-5: Spiral-Wrap Cable Ends

10. From the rear mast pulley, grasp the end of the damaged cable and carefully pull the new cable through the mast/pulley system until the new cable comes through the rear mast pulley and extends down to the winch.
11. Move the eyelet end of the cable up to the top of the front mast. Attach the eyelet of cable to the cable latch bracket using two 3/4" wrenches and cable eyelet retention bolt and hardware (see Figure 4-4).
12. Confirm the fork carriage is still at the lowest position and the mast locking arm is still engaged.
13. Thread new cable onto winch reel.
14. Rout the cable end through the winch reel gear plate. Make sure the cable is nested within the recess of the gear plate as shown in Figure 4-2. Using 7/16" wrench or socket, attach the winch rope clamp over cable and tighten.
15. Turn the winch handle and wrap the cable onto the reel. The cable must be wrapped a minimum of five full times around the reel while the fork carriage is at the lowest position. Make sure the cable is winds tightly and evenly on the drum. Make sure to wrap the cable to the outside of the reel as shown in Figure 4-6.
16. Using 1/2" wrenches or sockets, re-install the cable guard cover and confirm proper operation.



Figure 4-6: Cable Wrapped Tightly and Evenly

4.1.2 Replacing Broken Cable

If the cable broke while the lift was under load, the mast safety brake system activated and will need to be reset. Follow the instructions in *Section 6.7 MAST SAFETY BRAKE SYSTEM* in the material lift Operating Instructions and Parts Manual to release the mast safety brakes.

Break Occurs Between Front Mast Pulley and Fork Carriage:

If the cable break occurs between the front mast pulley and the fork carriage, the break should be visible. You can replace the broken cable with the mast in the vertical position. To replace the broken cable, follow steps 1 through 7, and steps 9 through 16 in *Section 4.1.1 Replacing Worn or Damaged Cable*.

Tools needed:

- 7/16" Wrench or Socket
- 1/2" Wrenches or Sockets
- 3/4" Wrenches or Sockets
- Electrical Tape

Break Occurs Inside Mast Assembly:

If the cable break occurs inside the mast assembly, between the front mast and the rear mast, the break will not be visible. To replace the cable, you will need to remove mast sections to find the break. Follow the instructions below to replace broken cable.

Tools needed:

- 7/16" Wrench or Socket
- 1/2" Wrenches or Sockets
- 3/4" Wrenches and Sockets
- 9/16" Wrench
- 3/8" Hex Wrench
- Electrical Tape
- Blue Loc-Tite®

Preparing to Replace Cable

1. Remove lifting fork from fork carriage.
2. Position the fork carriage at the lowest position.
3. Engage the mast locking arm. To do so, pull arm outward from its position at the rear of the mast. Rotate the arm forward and release when the rubber wheel is over the fork carriage. See Figures 4-7.
4. Using 1/2" wrenches or sockets, remove the rear cable guard shield to access the rear mast pulley.
5. Unwind the cable from the winch reel.
6. Using 7/16" wrench or socket, loosen and remove the winch rope clamp on the winch reel (see Figure 4-8). Remove the cable from the winch reel.



Figure 4-7: Engaging Mast Locking Arm

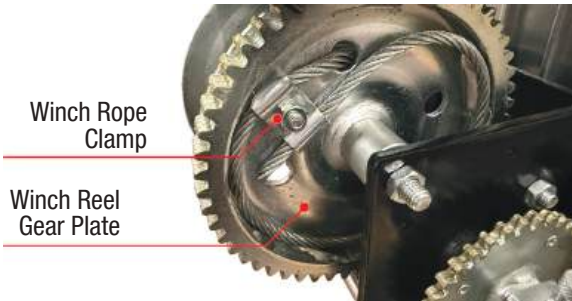

Figure 4-8: Winch Rope Clamp

7. **IMPORTANT:** You will need to lower the mast assembly to a near-horizontal position. Follow the steps 2 through 7 in *Section 7.2 PLACING LIFT IN HORIZONTAL TRANSPORT MODE* of the material lift Operating Instructions and Parts Manual. **NOTE:** Instead of laying the mast assembly in the fully-horizontal position, provide safe and secure bracing through the use of jack stands, pallets, or wood blocking to position the mast upper handle approximately three-feet from the floor (see Figure 4-9). This provides a slight angle to the mast assembly that will not allow the mast brakes to engage.



Figure 4-9: Mast Position

8. Locate the cable eyelet at the top of the front mast (see Figure 4-10). Using two 3/4" wrenches, remove the cable eyelet retention bolt to disconnect the cable eyelet from the mast (see Figure 4-11). Save the retention bolt and hardware for re-installation.
9. Pull the eyelet portion of the broken cable out of the mast assembly and discard.



Figure 4-10: Cable Eyelet Location

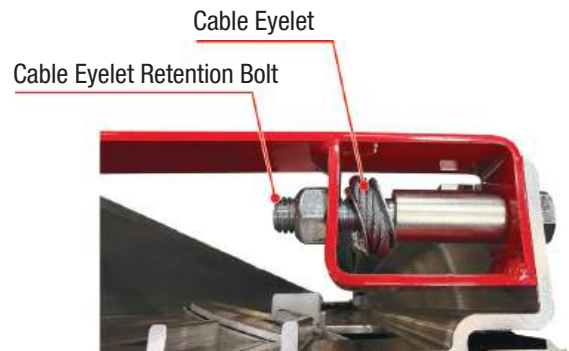

Figure 4-11: Cable Eyelet and Retention Bolt

Removing Mast Sections

10. Release the mast locking arm. Working from the bottom of the mast assembly and starting with the fork carriage, move each mast section up to reveal the next mast section's bottom slide stop blocks (see Figure 4-12). Using 3/8" hex wrench and 9/16" wrench, remove the two white plastic slide stop blocks from the mast beneath and remove the above mast section by sliding it away from the section beneath. Slide the sections from the bottom of the mast assembly. Repeat this until you find the section with the broken cable end.

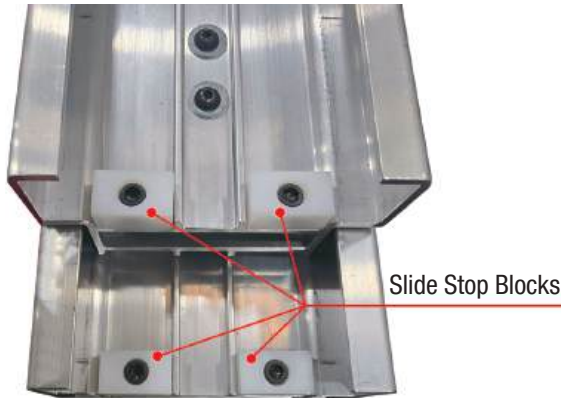

Figure 4-12: Slide Stop Blocks

Replacing Broken Cable

11. Lay the cut end of the new cable to the broken end of the damaged cable. Make sure there is a 1/4" gap between the two cable ends. Spiral-wrap the two cables together using electrical tape (see Figure 4-13).



Figure 4-13: Spiral-Wrap Cable Ends

12. From the rear mast pulley, grasp the end of the broken cable and carefully pull the new cable through the mast/pulley system until the new cable comes through the rear mast pulley. Pull enough new cable out to ensure the cable will not work back past the rear mast pulley and into the rear mast.
13. Remove the electrical tape from the cable splice and discard the old, broken cable.

Replacing Mast Sections and Routing Cable

14. Pull the eyelet end of the cable down to the bottom of the mast section.
15. Re-install the last mast section removed in step 10. Align the roller assemblies on each side at the top of mast section with the roller channels at the bottom of the mast beneath (see Figure 4-14). Slide the mast section about half way, making sure the lower pulley assembly is accessible from beneath the mast section.

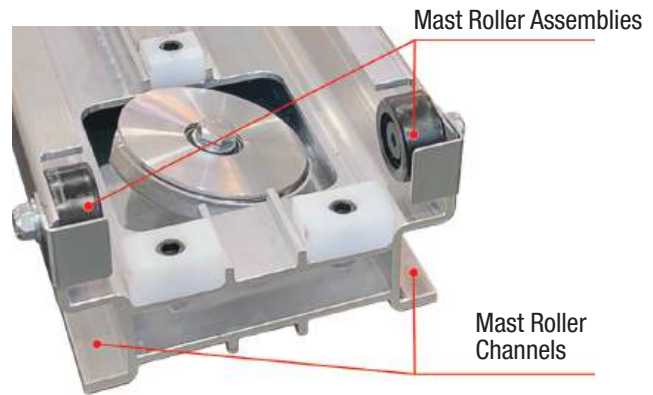

Figure 4-14: Mast Roller Assemblies and Mast Roller Channels

16. Using a 3/4" socket wrench, remove the upper and lower pulley assemblies of the re-installed mast section (see Figure 4-15). IMPORTANT: Be sure and note the placement of the three washers. Re-install washers in the same order (see Figure 4-16).

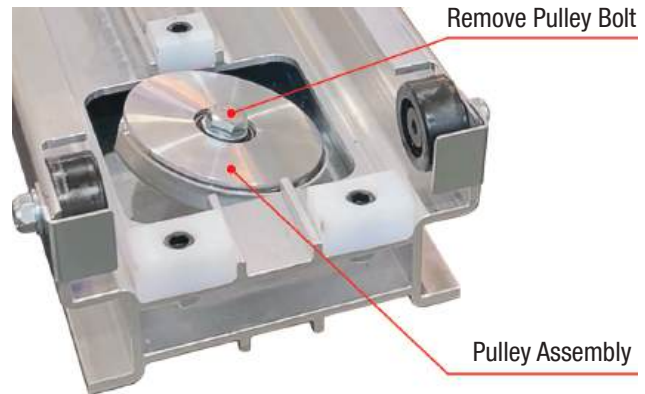

Figure 4-15: Removing Pulley Assemblies

17. Fish the eyelet end of the cable from the mast section beneath, down to the lower pulley opening of the re-installed mast section.
18. Apply a dab of blue Loc-Tite to the pulley bolt threads and loosely attach the lower pulley assembly back in place. NOTE: There is a small post on the pulley mount. Align that post with the mounting hole in the pulley shield (see Figure 4-16).

Make sure the pulley shield and pulley are very loose. Route the new cable around the bottom of the pulley. Press the pulley assembly together so that the pulley shield holds the cable in place on the pulley. Firmly tighten the 3/4" pulley assembly bolt. Make sure the pulley shield is rigid and tight and the pulley rotates freely.

19. Fish the cable up until it is visible in the upper pulley opening.
20. Apply a dab of blue Loc-Tite to the pulley bolt threads and loosely attach the upper pulley assembly back in place. NOTE: There is a small post on the pulley mount. Align that post with the mounting hole in the pulley shield (see Figure 4-16).

Make sure the pulley shield and pulley are very loose. Route the new cable around the top of the pulley. Press the pulley assembly together so that the pulley shield holds the cable in place on the pulley. Firmly tighten the 3/4" pulley assembly bolt. Make sure the pulley shield is rigid and tight and the pulley rotates freely.

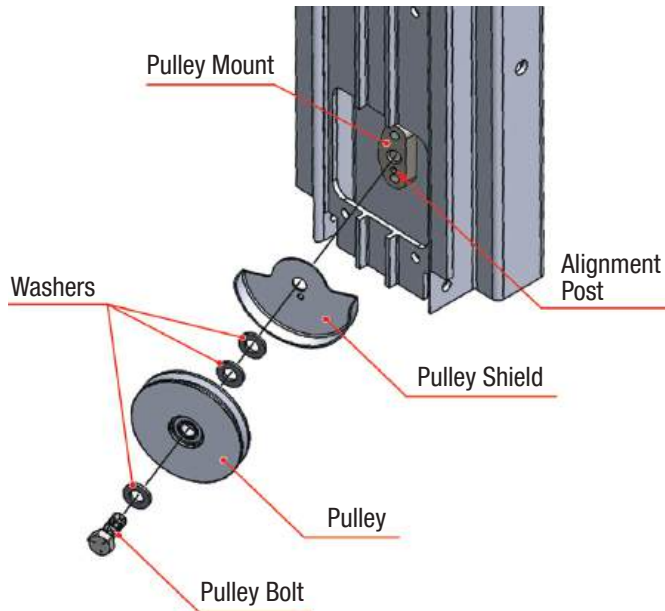

Figure 4-16: Pulley Assembly Parts and Installation Order

21. Move the top mast section up to expose the bottom of the mast beneath. Using 3/8" hex wrench and 9/16" wrench, re-install the two slide stop blocks (removed in step 10, see Figure 4-17) to the bottom of the mast assembly beneath. Do not overtighten the bolts and nuts as this may deform the slide stop block and cause unnecessary friction. Torque to 10 ft-lbs.
22. After re-installing each mast section, verify that the mast section will slide up freely and the cable moves freely through the pulleys.
23. Repeat steps 14 through 22 until you have the front mast section re-installed and the cable routed around the front mast's upper and lower pulleys.

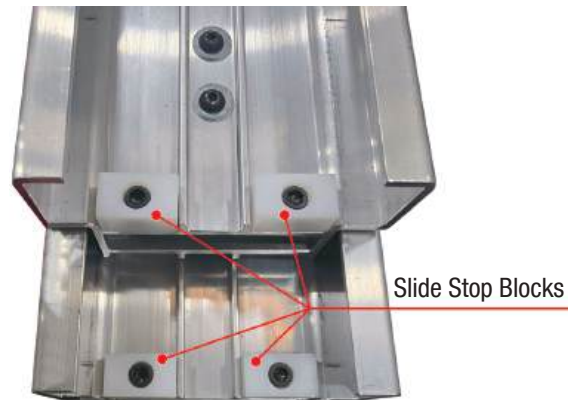

Figure 4-17: Slide Stop Blocks

Fork Carriage and Attaching Cable Eyelet

24. On the fork carriage, use a 3/4" socket wrench to remove the carriage pulley assembly. IMPORTANT: Be sure and note the placement of the three washers. Re-install washers in the same order (see Figure 4-16).
25. Apply a dab of blue Loc-Tite to the pulley bolt threads and loosely attach the carriage pulley assembly back in place. NOTE: There is a small post on the pulley mount. Align that post with the mounting hole in the pulley shield (see Figure 4-16).

Make sure the pulley shield and pulley are very loose. Route the new cable around the bottom of the pulley. Press the pulley assembly together so that the pulley shield holds the cable in place on the pulley. Firmly tighten the 3/4" pulley assembly bolt. Make sure the pulley shield is rigid and tight and the pulley rotates freely.

26. Re-install the carriage section to the front mast assembly. Align the roller assemblies on each side at the top of carriage section with the roller channels at the bottom of the front mast assembly (see Figure 4-18).

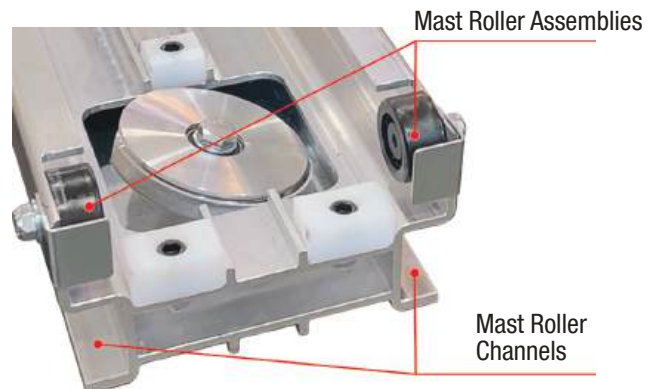

Figure 4-18: Mast Roller Assemblies and Mast Roller Channels

27. Slide the carriage section up to expose the bottom of the front mast assembly. Using 3/8" hex wrench and 9/16" wrench, re-install the two slide stop blocks (removed in step 10, see Figure 4-19) to the bottom of the front mast assembly. Do not overtighten the bolts and nuts as this may deform the slide stop block and cause unnecessary friction. Torque to 10 ft-lbs.
28. Move the eyelet end of the cable up to the top of the front mast. Attach the eyelet of cable to the cable latch bracket using two 3/4" wrenches and cable eyelet retention bolt and hardware (see Figure 4-20).

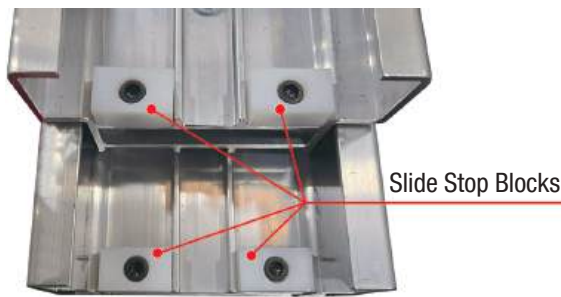

Figure 4-19: Slide Stop Blocks

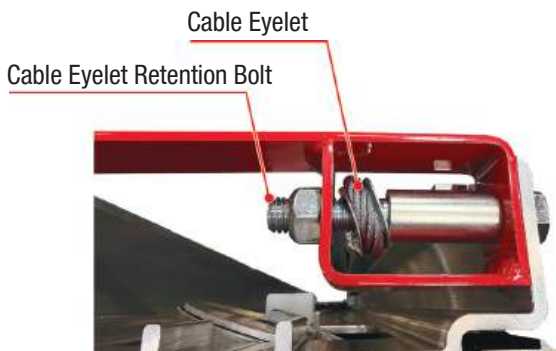

Figure 4-20: Cable Eyelet and Retention Bolt

Finishing

29. Move all mast sections and the fork carriage to the bottom of the mast assembly.
30. Engage the mast locking arm. To do so, pull arm outward from its position at the rear of the mast. Rotate the arm forward and release when the rubber wheel is over the fork carriage. See Figures 4-21.
31. Raise the mast assembly to the vertical position. See *Section 6.2.2 Preparing Material Lift from Horizontal Transport Mode* of the material lift Operating Instructions and Parts Manual.
32. Confirm the fork carriage is still at the lowest position and the mast locking arm is still engaged.
33. Thread new cable onto winch reel.



Figure 4-21: Engaging Mast Locking Arm

34. Rout the cable end through the winch reel gear plate. Make sure the cable is nested within the recess of the gear plate as shown in Figure 4-22. Using 7/16" wrench or socket, attach the winch rope clamp over cable and tighten.
35. Turn the winch handle and wrap the cable onto the reel. The cable must be wrapped a minimum of five full times around the reel while the fork carriage is at the lowest position. Make sure the cable is winds tightly and evenly on the drum. Make sure to wrap the cable to the outside of the reel as shown in Figure 4-23.
36. Using 1/2" wrenches or sockets, re-install the cable guard cover and confirm proper operation.
37. Re-install lifting fork to fork carriage.

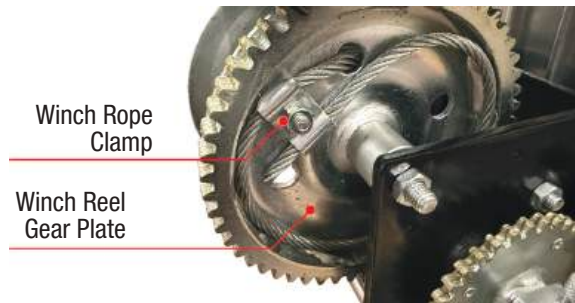

Figure 4-22: Winch Rope Clamp



Figure 4-23: Cable Wrapped Tightly and Evenly

4.2 CABLE PULLEY REPLACEMENT

Cable pulley assemblies are found on each mast section and on the fork carriage. The rear mast has one pulley assembly at the top. The middle and front mast each have pulley assemblies at the top and bottom. The fork carriage has one pulley assembly.

If a pulley assembly is damaged, follow the instructions below to replace. The replacement procedure is the same for pulley assemblies located at the top or bottom of the mast segment.

Tools needed:

- 3/4" Socket Wrench
- 9/16" Wrench
- 3/8" Hex Wrench
- Blue Loc-Tite®

1. You will need to have the mast assembly in a near horizontal position to access the mast section that contains the damaged pulley assembly. Follow the information in *Section 4.1.2 Replacing Broken Cable* on how to position the mast assembly, remove slide stop blocks, and slide the mast sections to gain access to a particular pulley assembly.

Upper pulley assemblies are located on the front of a mast section. Lower pulley assemblies are located on the back of a mast section.

You may need to feed out some of the cable from the winch in order to allow the mast segments to slide and move as needed.

2. Using a 3/4" socket wrench, remove the pulley bolt (see Figure 4-24).
3. Lift the pulley up and remove the cable, then remove and discard the pulley, washers, and pulley shield. **IMPORTANT:** Be sure and note the placement of the three washers. Re-install washers in the same order (see Figure 4-25).
4. For the new pulley assembly, apply a dab of blue Loc-Tite to the pulley bolt threads and loosely attach the new pulley assembly in place. **NOTE:** There is a small post on the pulley mount. Align that post with the mounting hole in the pulley shield (see Figure 4-25).

Make sure the pulley shield and pulley are very loose. Route the cable around the pulley. Press the pulley assembly together so that the pulley shield holds the cable in place on the pulley. Firmly tighten the 3/4" pulley assembly bolt. Make sure the pulley shield is rigid and tight and the pulley rotates freely.

5. Re-install any slide stop blocks removed to gain access to the pulley assembly. Do not overtighten the bolts and nuts as this may deform the slide stop block and cause unnecessary friction. Torque to 10 ft-lbs.

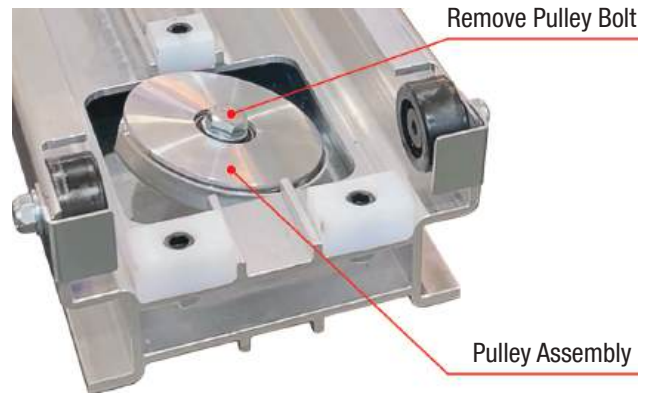

Figure 4-24: Removing Pulley Assemblies

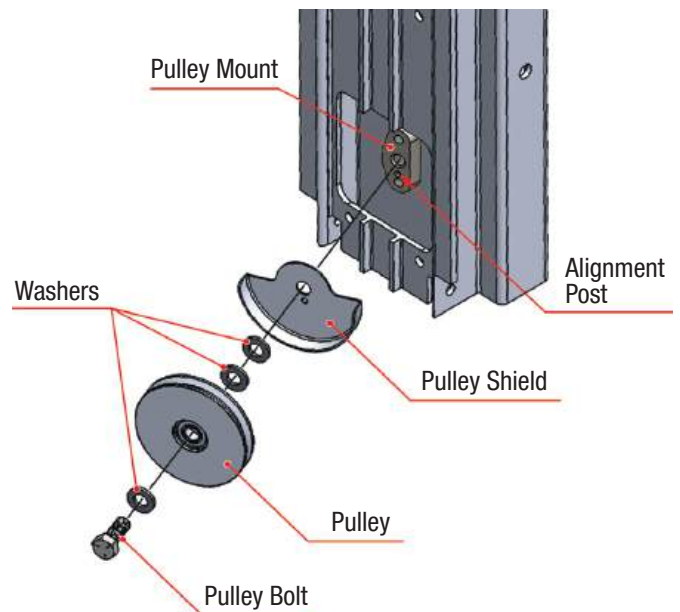

Figure 4-25: Pulley Assembly Parts and Installation Order

4.3 WINCH

4.3.1 Input Shaft and Outer Drive Gear Replacement

Tools needed:

- Flathead Screwdriver
- Needle-Nose Pliers
- 5/8" Thin-Wall Spark Plug Socket and Ratchet
- Locking Pliers
- Blue Loc-Tite®

Refer to Figures 4-26 through 4-29.

1. Remove any cable tension by winding out a portion of cable.
2. Using a flathead screwdriver and needle-nose pliers, remove and discard e-clips from input shaft. The e-clips are located against the input shaft bushings on the inside of the winch housing.
3. Remove and discard the input shaft and the input shaft bushings from the winch housing.
4. Replace new input shaft bushings, input shaft, and secure with e-clips. NOTE: Install bushings from the inside of the winch housing. The bushing flange must be on the inside of the winch housing.
5. Using locking pliers, clamp the winch reel to keep it from turning (see Figure 4-26).
6. Using 5/8" thin-wall spark plug socket and ratchet, remove the reel/hub nut and spring.
7. Remove and discard the outer drive gear and replace with new gear.
8. Apply a dab of blue Loc-Tite to the nut threads and secure outer drive gear with reel/hub nut and spring. Torque to 30 ft-lbs.
9. Remove locking pliers and confirm winch operates properly.
10. Apply a consistent layer of PC Peerless OG2 grease to the gear teeth of the winch reel gear, outer drive gear, and input shaft gear (see Figure 4-28).
11. Apply a light, even coat of mineral oil (3-in-1 oil or equivalent) to the winch drum shaft, outer drive gear shaft, and input shaft to ensure smooth rotation and prevent corrosion (see Figure 4-29).



Figure 4-26: Removing Outer Drive Gear

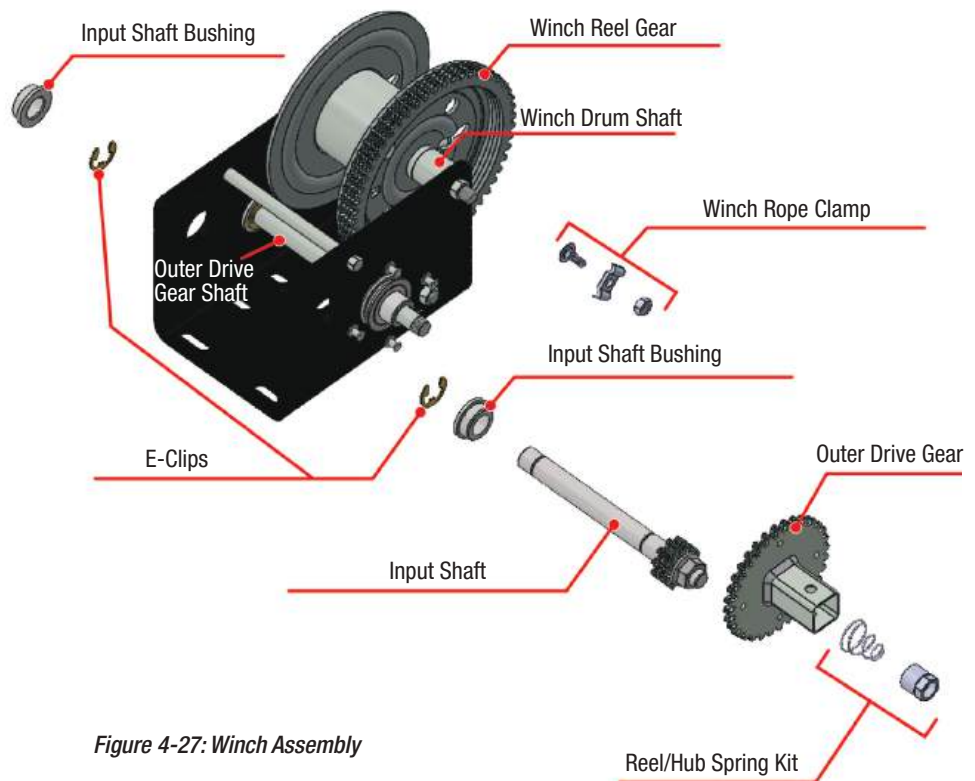

Figure 4-27: Winch Assembly

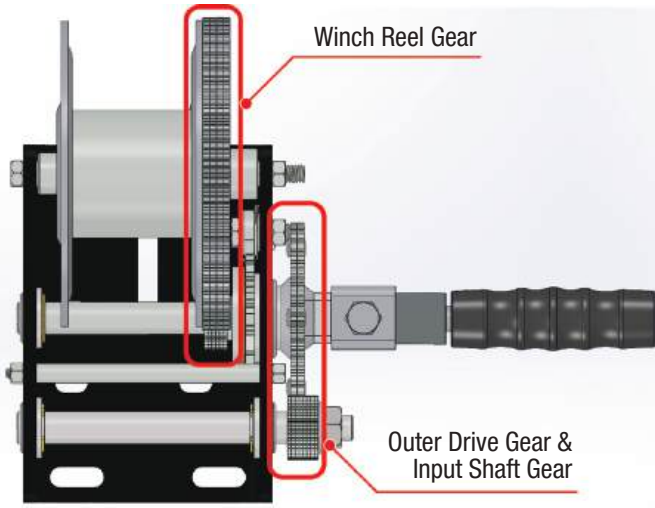

Figure 4-28: Grease Application

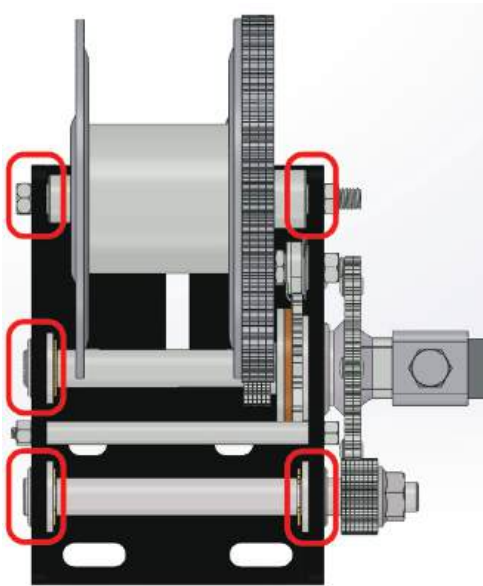

Figure 4-29: Mineral Oil Application Points

4.4 SLIDE BLOCK REPLACEMENT

The slide blocks prevent the mast sections from displacing from below or above the mast assembly. They also are guides for the mast sections to run upon.

If one or more slide blocks are damaged, follow the instructions below to replace.

Tools needed:

- 9/16" Wrench
- 3/8" Hex Wrench

1. You will need to have the mast assembly in a near horizontal position to access the mast section that contains the damaged slide blocks. Follow the information in *Section 4.1.2 Replacing Broken Cable* on how to position the mast assembly, remove slide stop blocks, and slide the mast sections to gain access to a particular area.

The slide blocks on the rear mast are located on the front of the mast. The slide blocks on the middle masts and front mast are located on the front and back of the mast. The slide blocks on the fork carriage are located on the back.

You may need to feed out some of the cable from the winch in order to allow the mast segments to slide and move as needed.

2. Move each mast section up or down to reveal the affected stop block(s) (see Figure 4-30 and Figure 4-31). Using 3/8" hex wrench and 9/16" wrench, remove the damaged white plastic stop block(s) and discard.
3. Using 3/8" hex wrench and 9/16" wrench, install the new slide block(s). Do not overtighten the bolts and nuts as this may deform the slide stop block and cause unnecessary friction. Torque to 10 ft-lbs.
4. Re-install any components removed to gain access to the damaged parts.

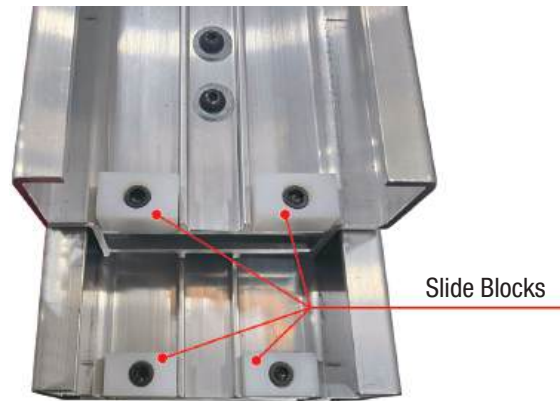

Figure 4-30: Slide Stop Blocks

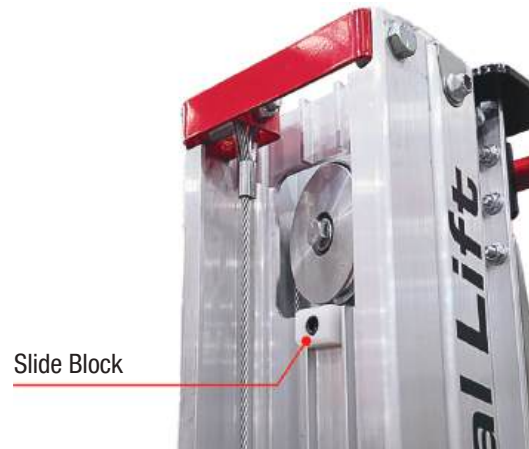

Figure 4-31: Slide Stop Block



JET TOOLS

427 New Sanford Road
LaVergne, Tennessee 37086
Phone: 800-274-6848

www.jettools.com