



Operating Instructions and Parts Manual BLVS Series Electric Hoists



JET
427 New Sanford Road
La Vergne, Tennessee 37086
Ph.: 800-274-6848
www.jettools.com

Document No. M-104000
Edition 3 05/2021
Copyright © 2020 JET



1.0 IMPORTANT SAFETY INSTRUCTIONS

WARNING: To avoid risk of injury:

1. Read and understand the entire owner's manual before attempting assembly or operation.
2. Read and understand the warnings posted on the machine and in this manual. Failure to comply with all of these warnings may cause serious injury.
3. Replace warning labels if they become obscured or removed.
4. This chain hoist is designed and intended for use by properly trained and experienced personnel only. If you are not familiar with the proper and safe operation of a chain hoist, do not use until proper training and knowledge have been obtained.
5. Do not use this chain hoist for other than its intended use. If used for other purposes, JET disclaims any real or implied warranty and holds itself harmless from any injury that may result from that use.
6. Do not install this chain hoist where explosive hazards may exist.
7. Give your work undivided attention. Looking around, carrying on a conversation and "horse-play" are careless acts that can result in serious injury.
8. Do not use to lift people, or loads over people. Warn others in the vicinity when lifting or transporting a load. Avoid swinging load and hook.
9. Do not exceed the rated lift capacity of the chain hoist.
10. Make sure limiter devices are operating properly. Do not use limit switches as routine operating stops; they are emergency devices only.
11. Verify that load chain is properly seated in load sheeve before operating hoist.
12. Do not use the load chain as a sling or wrap load chain around the load.
13. Do not use the load chain to side-pull a load.
14. Always inspect the chain hoist for damage prior to use. Do not use a chain hoist with twisted, kinked, worn or otherwise damaged chain. If the chain hoist is damaged, do not use until it has been repaired or replaced.
15. Do not use more than one chain hoist to lift or move a load. If this is unavoidable, *each* chain hoist must have the same capacity as the load to be moved.
16. Never allow the load chain to "set" over sharp edges. All lifts must be made with straight chain that is free of obstacles.
17. Do not use chain hoist unless load is centered between top and bottom hooks.
18. Protect load chain from weld splatter and other contaminants. Do not allow the hook or chain to be contacted by a live welding electrode.
19. Always take time to study the job to be performed and choose the safest method. Do not place yourself or other people in an unsafe position. Maintain constant awareness of the lifting environment.
20. Leave all internal maintenance to a qualified JET service center.
21. Disconnect hoist from power source before performing maintenance or opening the housing.
22. Do not leave a suspended load unattended.
23. Replace the chain with factory replacement chain only. Do not use any other type of chain.
24. Never use the chain hoist if either hook is stretched, deformed, or has a broken or missing safety latch. Always replace the safety latch and/or the hook before placing the chain hoist back into service.
25. Keep safety guards in place at all times when the hoist is in use.
26. Do not operate this hoist while tired or under the influence of drugs, alcohol or any medication.
27. This hoist is not designed for exposure to outdoor elements.
28. Understand and follow all procedures as set forth in American National Standards titled *Overhead Hoists (Underhung)*, ANSI/ASME B30.16. This standard is available through the American Society of Mechanical Engineers at www.ASME.org.

⚠ WARNING: This product can expose you to chemicals including lead and cadmium which are known to the State of California to cause cancer and birth defects or other reproductive harm, and phthalates which are known to the State of California to cause birth defects or other reproductive harm. For more information go to <http://www.p65warnings.ca.gov>.

Familiarize yourself with the following safety notices used in this manual:

⚠ CAUTION This means that if precautions are not heeded, it may result in minor injury and/or possible machine damage.

⚠ WARNING This means that if precautions are not heeded, it may result in serious injury or possibly even death.

2.0 Important Notice

It is the responsibility of the owner/user to install, inspect, operate and maintain this hoist in accordance with OSHA regulations and ANSI/ASME B30.16, "Overhead Hoists (Underhung)", along with any state or local codes/ordinances as applicable. If hoist is installed as part of a total lifting system (trolley, crane, monorail, etc.), or if below-the-hook lifting devices will be used, it is the responsibility of the owner/user to comply with any standards or regulations involving those additional elements of the system.

3.0 About This Manual

This manual is provided by JET covering the safe operation and maintenance procedures for the JET BLVS series hoists. This manual contains instructions on installation, safety precautions, general operating procedures, maintenance instructions and parts breakdown for your hoist. It is not intended to be an exhaustive guide to the use of hoists or the broad subject of rigging, and cannot anticipate every system or lifting configuration in which this product may be used.

Retain all instructions and safety warnings for continued reference. If the hoist transfers ownership, the manual should accompany it.

If there are questions or comments, please contact either your local supplier or JET. JET can also be reached at our web site: www.jettools.com.

⚠ WARNING Read and understand the entire contents of this manual before installing hoist or attempting operation, adjustment or maintenance. Failure to comply may cause serious injury.

4.0 Table of Contents

Section	Page
1.0 IMPORTANT SAFETY INSTRUCTIONS	2
2.0 Important Notice	3
3.0 About This Manual	3
4.0 Table of Contents	4
5.0 Product Introduction	5
6.0 Glossary	5
7.0 BLVS Series Hoist Specifications	6
7.1 BLVS 1/8, 1/4, and 1/2 Ton – Dimensions (in.)	6
7.2 BLVS 1/8, 1/4, and 1/2 Ton – Specification Chart	7
7.3 BLVS 1 and 2 Ton – Dimensions	8
7.4 BLVS 1 and 2 Ton – spec chart	9
7.5 Operating Environment	10
7.6 Wireless Controller Specifications	10
8.0 Unpacking	11
8.1 Shipping Contents	11
9.0 Installation	11
9.1 Mounting Top Hook	11
9.2 Lubrication	11
9.3 Power Cable	11
9.4 Controller Setup	12
9.5 Chain Container	12
10.0 Electrical Connections	12
10.1 Grounding Instructions	12
10.2 Inspecting Hoist Motion	13
11.0 Pre-Operation Inspection	13
11.1 Inspecting Load Chain	13
11.2 Inspecting Hooks	13
12.0 Operation	14
12.1 Controls	14
12.2 General Procedure	14
12.3 Load Brake Function	15
12.4 Overload Protection	15
13.0 Adjustments	15
13.1 Replacing Load Chain	15
14.0 Transmitter/Receiver Synchronization	18
15.0 Mechanical Classification (Grade)	19
16.0 Inspection and Maintenance	20
16.1 Gearbox Oil	20
17.0 Inspection Schedules	21
18.0 Allowable Limits	22
18.1 Hook Wear Limits (Top and Bottom)	22
18.2 Chain Wear Limits	23
19.0 Chain Container Selection for BLVS Series Hoist	24
20.0 Controllers for BLVS Hoists	24
21.0 Troubleshooting BLVS Series Hoists	25
22.0 Replacement Parts	26
22.1.1 BLVS018 and BLVS025 Hoists – Exploded View	27
22.1.2 BLVS018 and BLVS025 – Parts List	28
22.2.1 BLVS050 Hoist – Parts List	30
22.2.2 BLVS050 Hoist – Parts List	31
22.3.1 BLVS018, 025, 050 Hoist – Exploded View II	33
22.3.2 BLVS018, 025, 050 Hoist – Parts List II	33
22.4.1 BLVS100 & 200 Motor & Housing – Exploded View	34
22.4.2 BLVS100 & 200 Motor & Housing – Parts List	35
22.5.1 BLVS100 & 200 Hook – Exploded View	36
22.5.2 BLVS100 & 200 Hook – Parts List	37
22.6.1 BLVS100 & 200 Load Chain – Exploded View	38
22.6.2 BLVS100 & 200 Load Chain – Parts List	39

22.7.1 BLVS100 & 200 Gear Box – Exploded View.....	40
22.7.2 BLVS100 & 200 Gear Box – Parts List.....	41
22.8.1 BLVS100 & 200 Electric – Exploded View	42
22.8.2 BLVS100 & 200 Electric – Parts List.....	43
23.0 Electrical connections for BLVS series hoist.....	44
23.1 BLVS018, 025, 050 Wiring Diagram	44
23.2 BLVS100, 200 Wiring Diagram	45
24.0 Warranty and Service.....	46

5.0 Product Introduction

Your JET variable speed hoist is designed and constructed to provide consistent, long-term operation if used in accordance with the instructions set forth in this manual.

JET BLVS series hoists are variable speed, available in 120 volt, single-phase power, and varied chain lengths.

The mechanical load brake prevents slippage up to maximum load capacity. The hoist is also provided with overload protection and limit switches.

This hoist complies with FEM standards.

6.0 Glossary

Key terms the hoist operator should know:

Creep speed: Slow, constant, fixed rate of motion of a hoist.

Duty cycle: The amount of work a hoist can perform in a given period of time, generally measured by maximum run time and number of starts within that period. Duty cycle *ratings* are designated H1 through H5.

Duty class: Identifies the type of service for which a hoist is designed, designated A through F.

Headroom: Minimum distance between saddle of top hook to saddle of load hook, measured when load hook is at upper travel limit. Smaller headroom allows a hoist to fit in tighter work spaces.

Hook saddle: The inside arc of the hook which contacts the beam (top hook) or where the load sling is seated (load hook).

Toggle or “bump fire”: Rapid press and release of a control button to raise or lower load in intermittent steps. (A variable frequency drive in lowest speed range often eliminates the need for toggling.)

Overtravel limit device: A device for limiting upward or downward travel of the load hook at the extremities of its lift. (If activation of the device alters the electrical circuit within the machine, it is often called a “limit switch.”)

Load block: The assembly of hook or shackle, swivel, bearing, pins, sheaves and frame suspended by the chain.

Overload limit device: A mechanical or electrical device that prevents the hoist from lifting when excessive load is applied.

Rated Load, or Capacity: The maximum load weight, usually labeled as tonnage, which the hoist is designed to handle as designated by the manufacturer.

Reeving: The system in which a chain or rope travels around a running sheave.

Running Sheave: A sheave which engages the chain/rope and rotates as the load block is raised or lowered. Also called “load sheave” or “load sprocket.”

Variable frequency drive (“inverter”): A control system that converts fixed line voltage and frequency into a three-phase system with infinitely variable voltage and frequency, in order to regulate motor speed.

The specifications in this manual were current at time of publication, but because of our policy of continuous improvement, JET reserves the right to change specifications at any time and without prior notice, without incurring obligations.

7.0 BLVS Series Hoist Specifications

7.1 BLVS 1/8, 1/4, and 1/2 Ton – Dimensions (in.)

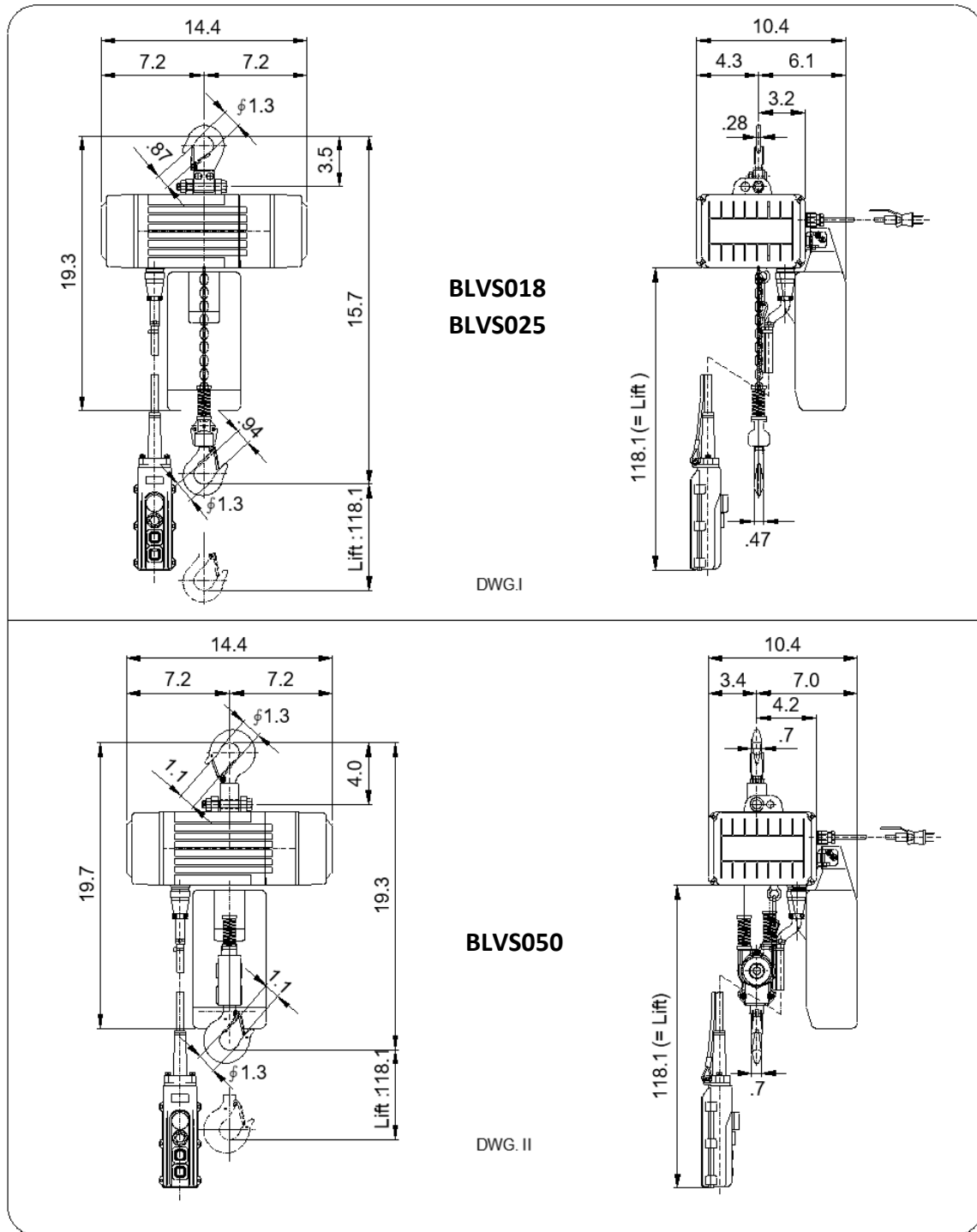

Figure 7-1: All dimensions in inches. (Shows OPTIONAL wired pendant; wireless remote comes standard.)

7.2 BLVS 1/8, 1/4, and 1/2 Ton – Specification Chart

Refer to Figure 7-1

		BLVS018	BLVS025	BLVS050
DWG. Figure 7-1		I	I	II
Capacity		1/8 Ton (120kg)	1/4 Ton (240kg)	1/2 Ton (480kg)
Lift		All models available in standard 10 or 20 ft. lifts. Custom lengths up to 100 ft. some models ¹		
Load Chain diameter x pitch	in.	Ø .157 x .47		
	mm	Ø 4.0 x 12		
Number of falls		1	1	2
Lifting speeds	Low speed	4.1~10.5 ft/min (1.25~3.2 m/min)	4.1~10.5 ft/min (1.25~3.2 m/min)	2.07~5.25 ft/min (0.63~1.6 m/min)
	High speed	41 ft/min (12.5 m/min)	41 ft/min (12.5 m/min)	20.67 ft/min (6.3 m/min)
Pendant controls		Wireless controller ²		
Net weight	10 ft. Lift	36.4 lb (16.5kg)		42.8 lb (19.4kg)
	20 ft. Lift	38.6 lb (17.5kg)		47.4 lb (21.5kg)
Shipping weight	10 ft. Lift	43.0 lb (19.5kg)		49.4 lb (22.4kg)
	20 ft. Lift	45.4 lb (20.6kg)		54.0 lb (24.5kg)
Duty Cycle	Time Rating	15 min.		
	Duty Rating	H3 (30%)		
	Max. starts per hour	180		
Motor	Horsepower	0.4 HP (300 W)	0.8 HP (600 W)	0.8 HP (600 W)
	Pole	8P	8P	8P
	Cycle	60Hz		
	Phase	Single		
	Voltage	115 V		
Current Draw (amperage)		6.0 A	10.0 A	10.0 A
Noise level ³		81 dB		
Gearbox capacity		0.5 L		
Oil reservoir capacity		500 CC (±10%)		
Enclosure ratings	Hoist	IP54		
	Pushbutton control	IP65		

Table 1

¹ Stock numbers vary based upon chain length. Determine needs, then see JET website for stock numbers. Note: Some models are shipped in a plastic molded carrying case.

² Optional wired pendants also available. See sect. 20.0.

³ Measured at 1m horizontally from hoist during normal operation. The specified values are emission levels and are not necessarily to be seen as safe operating levels. As workplace conditions vary, this information is intended to allow the user to make a better estimation of the hazards and risks involved only.

7.3 BLVS 1 and 2 Ton – Dimensions

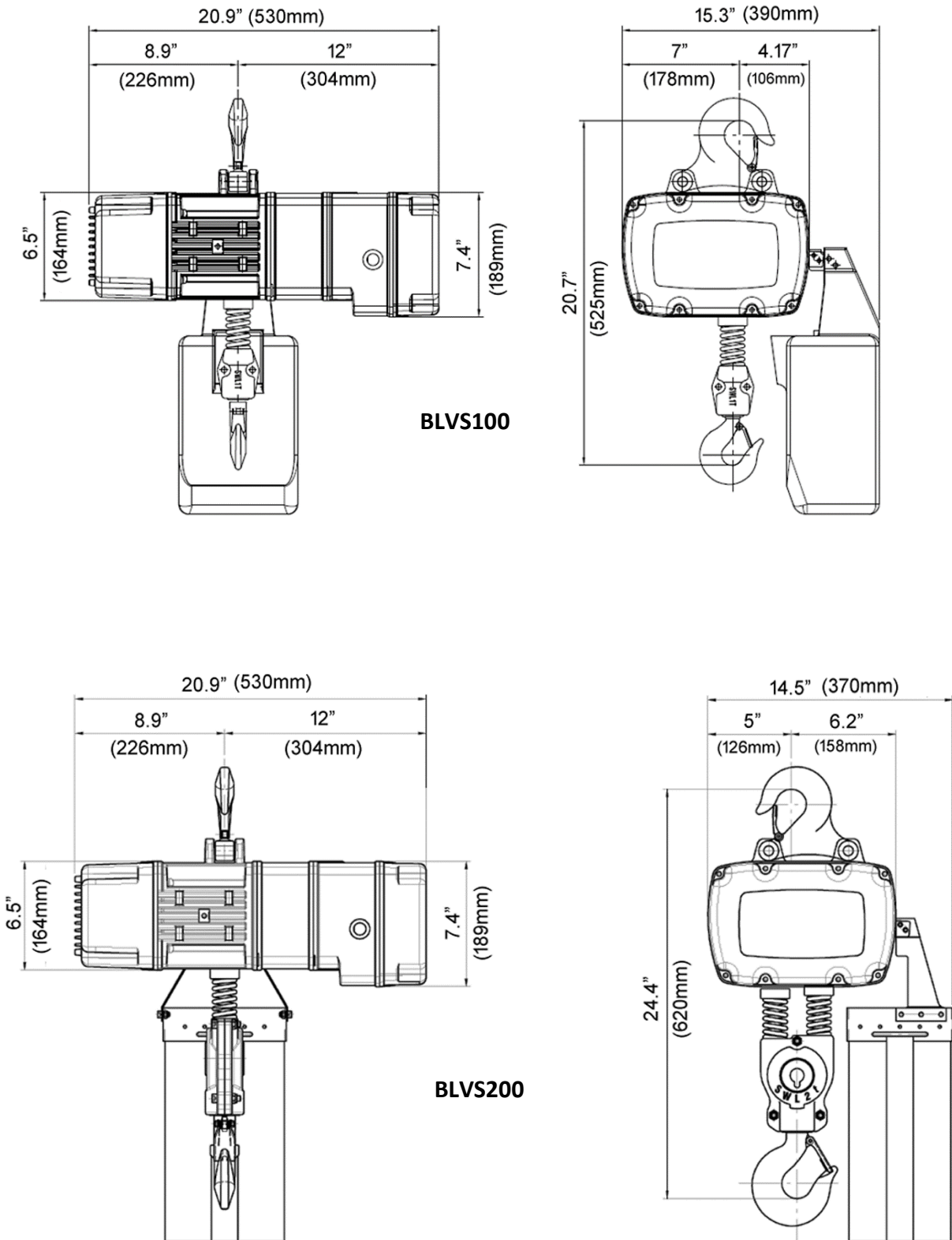

Figure 7-2

7.4 BLVS 1 and 2 Ton – spec chart

See Figure 7-2

		BLVS100	BLVS200
Capacity		1 Ton (1000kg)	2 Ton (2000kg)
Lift		All models available in standard 10 or 20 ft. lifts. Custom lengths up to 100 ft. some models ¹	
Load Chain diameter x pitch	in.	Ø .279 x .795	
	mm	Ø 7.1 x 20.2	
Number of falls		1	2
Lifting speeds	Low speed	1.84~4.59 ft/min (0.56~1.4 m/min)	0.92~2.3 ft/min (0.28~0.7 m/min)
	High speed	18.4 ft/min (5.6 m/min)	9.18 ft/min (2.8m/min)
Pendant controls		Wireless controller ²	
Net weight	10 ft. Lift	118 (53.5kg)	127 (57.6kg)
	20 ft. Lift	128 (58.1kg)	153 (69.4kg)
Shipping weight	10 ft. Lift	173 (78.5kg)	183 (83.1kg)
	20 ft. Lift	183 (83.1kg)	208 (94.3kg)
Duty Cycle	Time Rating	15 min.	
	Duty Rating	H3 (30%)	
	Max. starts per hour	180	
Motor	Horsepower	1.34 HP (1000W)	1.34 HP (1000W)
	Pole	8P	
	Cycle	60Hz	
	Phase	Single	
	Voltage	115 V	
Current Draw (amperage)		15.0 A	
Noise level ³		81 dB	
Gearbox capacity		0.7 L	
Oil reservoir capacity		800 CC (±10%)	
Enclosure ratings	Hoist	IP54	
	Pushbutton control	IP65	

Table 2

¹ Stock numbers vary based upon chain length. Determine needs, then see JET website for stock numbers. Note: Some models are shipped in a plastic molded carrying case.

² Optional wired pendants also available. See sect. 20.0.

³ Measured at 1m horizontally from hoist during normal operation. The specified values are emission levels and are not necessarily to be seen as safe operating levels. As workplace conditions vary, this information is intended to allow the user to make a better estimation of the hazards and risks involved only.

7.5 Operating Environment

Working temperature range: -5 to +40 °C (23 to 104 °F)

Working humidity range: 85% or less

Electric power supply: Single phase, 100V~240V(+/-10%), 60Hz

7.6 Wireless Controller Specifications

Frequency range	902.5 ~ 927.5 MHz	Average power consumption	16mA@DC3V (default setting)
Modulation method	2 GFSK	Radio-frequency power	<10dBm (default setting)
Operating range	328 ft. (100 m)	Operating temperature	-4° ~ +131°F (-20° ~ +55°C)
Control system	PLL	Storage temperature	-40° ~ +149°F (-40° ~ +65°C)
Antenna impedance	50 Ω	Enclosure rating	IP65
Typical command response time	50mS~100mS	Dimensions	7.6x2.24x2 in. (193x57x51 mm)
Power supply	LR6(AA)1.5Vx2	Weight (including battery)	0.72 lb (325 g) approx.
Antenna	internal	Housing material	PA6 (30%GF)

Table 3

⚠WARNING

Read and understand the entire contents of this manual before installing hoist or attempting operation. Failure to comply may cause serious injury.

8.0 Unpacking

Remove hoist from its crate or case and carefully inspect its components for shipping damage. Report any damage immediately to your distributor and shipping agent. Do not discard any shipping material until hoist is installed and running properly.

8.1 Shipping Contents

- 1 Electric chain hoist
- 1 Chain container with fasteners
- 1 Power supply cord
- 1 Wireless controller
- 1 Wrist strap (for controller)
- 1 Receiving antenna
- 1 Top hook assembly
- 1 Bottom hook assembly with chain
- 1 Hoist instructions & parts manual
- 1 Remote controller manual
- 1 Product registration card
- 1 Test certificate

9.0 Installation

⚠WARNING

Hoist must remain disconnected from electrical supply during assembly and installation unless instructed otherwise.

Support for the hoist may be hook, clevis pin, trolley, or beam clamp. Whatever method of suspension is chosen, the support components **must** be rated equal to, or greater than the capacity of the chain hoist. Supporting structures (such as I-Beams) should be installed by properly licensed professional installers.

If you are using the hoist with a trolley, refer to the trolley manual for instructions on securing the control cord and maintaining proper slack in the cord during operation. Optional pendant cords for use with a trolley system are shown in *section 20.0*.

TIP: If suspending from a trolley, do not mount the top hook but install the hoist directly to the trolley if possible.

Make sure the suspension system used is properly grounded, in addition to the grounding of the hoist.

9.1 Mounting Top Hook

Attach the top hook with the provided lock bolt, hex nut and cotter pin (Figure 9-1).

9.2 Lubrication

9.2.1 Gear Oil

Your hoist has been shipped with oil included in the gearbox. Before operating, verify the oil level by removing the fill plug on top of the hoist, shown in Figure 9-1. The oil level should be just below the edge of the hole.

Check the level again after the first 100 hours of operation, then check every 3 months. See *sect. 16.1* for oil specifications.

IMPORTANT: Before operating hoist, pull out the rubber breather plug from the top fill plug (Figure 9-1). Reinsert this plug if hoist is to be transported or placed in storage.

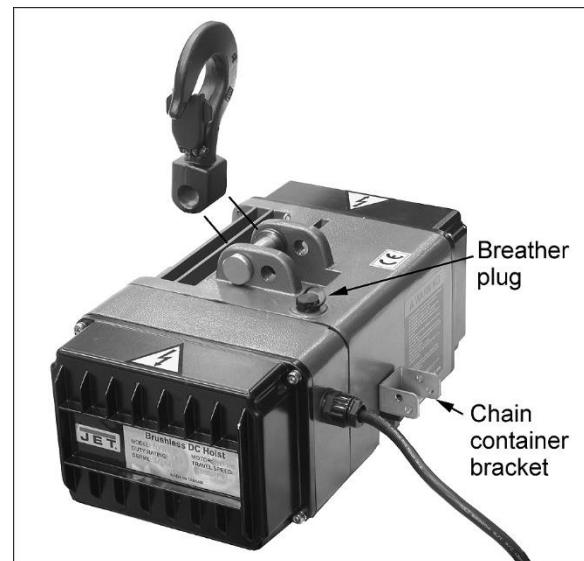

Figure 9-1 (BLVS050 shown)

9.2.2 Chain Lubrication

Periodically apply a light coat of 30W oil to the chain. This will create easier operation and prolong the chain's life. For optimum results, clean chain with an acid-free solution before oiling.

9.3 Power Cable

⚠WARNING

All electrical connections must be made by qualified personnel. Read *sect. 10.0* before connecting this unit to power.

Connect the power cable leads to an extension and run the line to the electrical panel, or install a UL/CSA approved plug to draw from a receptacle.

IMPORTANT: The power cable should be directed so that it is safely out of the way of loads. If a trolley is used, power cable must not interfere with, or be pinched by, trolley travel. See Figure 9-2 for a recommended solution.

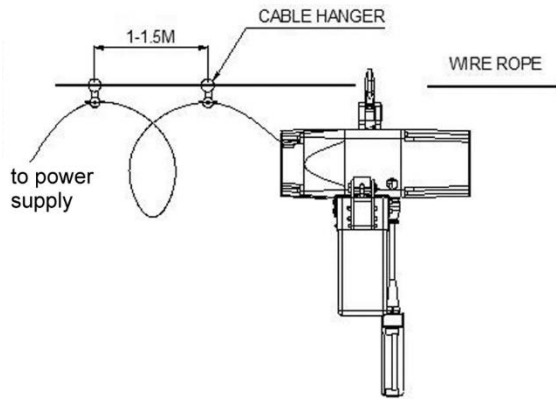

Figure 9-2

9.4 Controller Setup

Screw the receiving antenna onto the bottom of the hoist. See Figure 9-3. The wrist strap can be placed on the wireless controller.

The wireless controller (transmitter) has been synchronized to your specific hoist by the manufacturer. If replacing a transmitter, see sect. 14.0 for instructions.

If using a *wired pendant* controller (optional accessory), the antenna is not needed. Connect the 12-pin male plug on the controller cable to the receptacle beneath the hoist, and clip the carabiner to the eye bolt to relieve stress on the plug connection.

See sect. 12.1 for controller operation.



Figure 9-3: remote controller setup

9.5 Chain Container

Your hoist is supplied with a chain container designed to fit the particular length of chain. If a different length chain is ever installed on this hoist, the chain container must be replaced by one of proper size. See chart in sect. 19.0.

The chain container should be installed *after* the power supply is connected to hoist.

WARNING Do not overfill chain container. If chain should overfill and begin to fall, entire chain container may empty without warning,

resulting in serious personal injury or property damage.

To assemble chain container to hoist:

1. Hang hoist in position on the I-Beam or trolley. Do not install chain container yet. Allow slack side and load side of chain to hang freely from hoist.
2. Apply power to hoist and press DOWN button until limit switch is tripped.
3. Mount chain container to bracket on side of hoist (Figures 9-1 and 9-4), using the two socket head bolts and lock washers.
4. Place chain stop into container, and operate hoist to bring load hook up until upper limit switch is tripped.
5. Inspect chain to ensure that all non-loaded chain is completely in container.

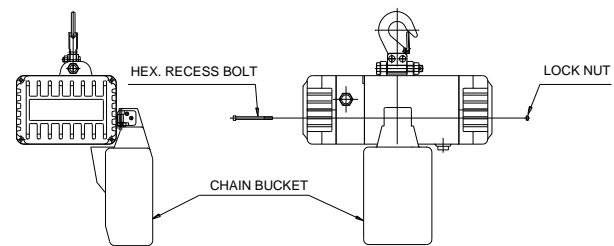

Figure 9-4

CAUTION Do not dump chain by hand into the chain container. By not following the above steps, the chain can become twisted or kinked and can damage the hoist.

10.0 Electrical Connections

WARNING Electrical connections must be made by a qualified electrician in compliance with all relevant codes. This machine must be properly grounded to help prevent electrical shock and possible fatal injury.

The BLVS series hoist is pre-wired for 120V, single-phase power only.

The hoist should be connected to a circuit with current overload protection, rated at minimum 120% of the full load amperage listed on the hoist's nameplate. If fuses are used, they must be time-delay fuses rated "D". **Local codes take precedence over recommendations.**

10.1 Grounding Instructions

In the event of a malfunction or breakdown, grounding provides a path of least resistance for electric current to reduce the risk of electric shock.

This hoist is not supplied with a power plug. Power supply cables may either be fitted with a UL/CSA-listed plug rated for the appropriate phase and voltage, or "hard-wired" directly to a control panel. If

hard-wired, make sure a disconnect is available for the operator.

If a plug is installed, it must have an equipment-grounding conductor and a grounding prong. The plug must be plugged into a matching outlet that is properly installed and grounded in accordance with all local codes and ordinances. Do not modify the plug – if it will not fit the outlet, have the proper outlet installed by a qualified electrician.

Improper connection of the equipment-grounding conductor can result in a risk of electric shock. The conductor with insulation having an outer surface that is green with or without yellow stripes is the equipment-grounding connector.

If repair or replacement of the electric cord or plug is necessary, do not connect the equipment-grounding conductor to a live terminal.

Check with a qualified electrician or service personnel if the grounding instructions are not completely understood, or if in doubt as to whether the tool is properly grounded.

Repair or replace damaged or worn cord immediately.

10.2 Inspecting Hoist Motion

1. Allow 15 seconds for start-up after connecting power supply.
2. Before closing circuit breaker and testing hoist, check that wiring has been complete. If hoist cannot be observed when circuit breaker is closed, station an observer within sight of hoist to report any movement when power is applied. Be prepared to disconnect power if hoist motor starts when power is applied – the hoist must remain motionless when power is applied. Find and correct any problems before continuing.
3. With no load on load hook, press UP button very briefly and observe hoist action. The hook should move upward.
4. Run hoist to maximum lifting height, then to maximum lowering point to ensure that limiter devices are operating properly.

11.0 Pre-Operation Inspection

11.1 Inspecting Load Chain

Clean chain with non-acidic solution, and carefully inspect entire load chain. Replace damaged chain before using hoist. Use provided chain gauge and refer to *sect. 18.2*. Replace worn chain.

Also replace the load chain if any of the following are identified:

1. Seriously rusted or cracked.
2. Marks on the chain surface are deeper than 5% of the link's diameter.

3. Links are twisted or deformed.
4. Links are stretched too long or considerably worn on the surface, especially at points where links contact each other.

Never extend load chain by welding a second piece to the original.

⚠ WARNING Do not operate hoist with twisted, kinked or damaged load chain. Do not splice load chain.

Check that chain does not twist along its length from hoist to hook (Figure 11-1). If twist is present on units with multiple falls, the hook has been capsized; it must be passed back through the chain loop to remove all twist in the chain. See Figure 11-2.

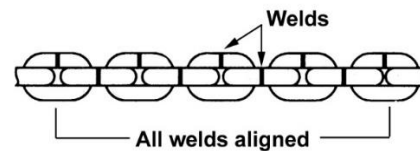

Figure 11-1

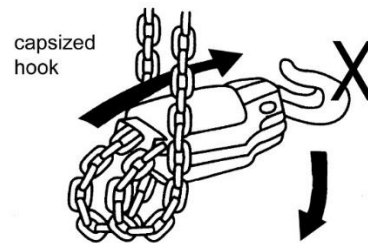

Figure 11-2

⚠ WARNING The load chain supplied with your JET chain hoist is designed, manufactured, and tested for proper fit and durability. Over a period of time, the chain may need to be replaced. For your own safety, use factory replacement chain only. Use of other than factory replacement chain may cause serious injury and/or damage to hoist.

A light coat of 30W oil applied periodically to the chain will create easier operation and prolong chain life.

11.2 Inspecting Hooks

It is important to check top and bottom hooks for proper opening and other signs of deformation or damage. Replace a hook immediately if any of the following problems are identified:

1. The safety latch is damaged or bent, or no longer has sufficient spring pressure to contact the hook tip.
2. The vertical angle at neck of the hook reaches 10° (see Figure 11-3).

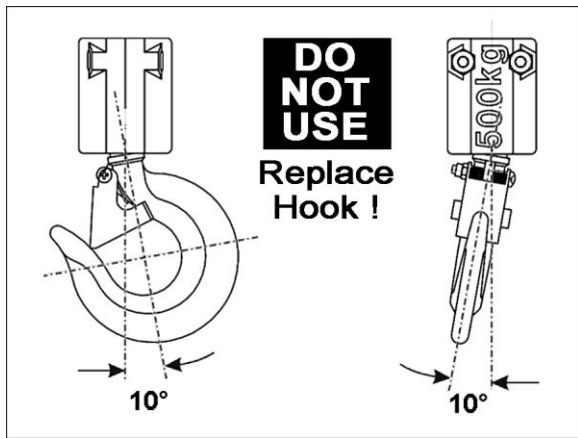

Figure 11-3

3. Chemical corrosion or cracks on the hook.
4. Excessive wear on the inside surface.
5. The throat opening has enlarged. (See sect. 18.1 for maximum allowable limits for the throat opening.)

NOTE: Excessive hook throat opening or twist indicates abuse or overloading of the hoist. If such deformation is discovered, inspect hoist, chain and all supporting members very carefully for additional indications of excessive hoist loading.

⚠ WARNING Do not attempt repair of a hook by heat treating, bending or attaching anything by welding. Such procedures will weaken and may cause failure of the hook.

12.0 Operation

Read all safety instructions in sect. 1.0 before operating this hoist.

12.1 Controls

Refer to Figure 12-1.

⚠ CAUTION Allow hoist to come to a full stop before changing direction. Rapidly reversing or catching a falling load can overload the hoist system and cause failure in hoist and/or chain, resulting in injury or property damage.

The wireless controller is provided with the hoist. An optional wired pendant controller is available. See sect. 20.0.

Press START on wireless controller. To lift a load, press and hold the UP button. To lower, press and hold the DOWN button. Adjust speed using the dial.

Pressing START button during operation will sound the horn.

Press and hold a button firmly; avoid excessive inching. Allow at least one second before switching

between UP and DOWN buttons; hoist will not move if the transition is too quick.

The UP and DOWN buttons are two-step. Press lightly for slower speed, press fully for faster speed.

Press the red emergency stop button (“E-stop”) to shut off power; the button remains locked and prevents any movement of the hoist. To restart, rotate stop button clockwise until it disengages.



Figure 12-1

The wireless controller has a “zero-G” sensor: If the unit is dropped, thrown, or receives a sudden impact, commands will be disabled, to prevent accidental hoist movement.

The wireless controller is powered by (2) AA batteries, which may require occasional replacement.

12.2 General Procedure

If hoist is connected to a manual trolley, move hoist by pushing on the suspended load. Move an unloaded hoist by pulling on the empty hook. Do **NOT** move hoist by pulling on control cord.

Always keep hoist clean, and store in a clean, dry location.

Avoid lifting one load with two hoists. If this is unavoidable, apply equal weight to both hoists and use hoists with proper lift capacity. **Capacity of each hoist must be equal to the total load to be lifted.**

Follow this general procedure for hoisting loads:

1. Secure upper hook to the supporting structure.

- Place load sling or chain in center of bottom hook, making sure the safety latch is secure. **Never load the hook in front of the safety latch.** See Figure 12-2.

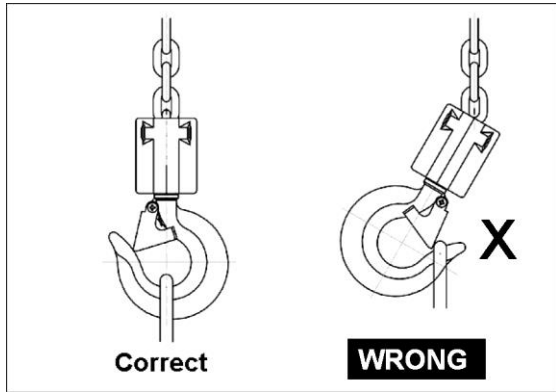

Figure 12-2

- Press UP button (slow speed) and remove all slack in load chain. Increase tension in load chain until hoist is about to raise the load.
- Check again that load is properly slung, is directly under hoist, and will not suddenly swing or twist.
- Raise load an inch or two above ground and stop. Observe load for a few moments, looking for signs that load or hoist system is unstable, or other indications of a problem.
- Check that chain is not twisted at bottom hook. All welds should face same direction (see Figure 11-1). For hoists with two or more falls of chain, make sure bottom hook is not capsized. This may cause the chain to twist.
- Raise load to traveling height. Raise only to height necessary to safely clear all obstacles.
- Lower load at destination. If both UP and DOWN commands must be used during lowering, pause for a moment between each reversal of load direction.
- Slowly allow weight to shift from hoist to ground or new support. Do not approach load until all tension is out of chain and load is stable.
- Press red stop button to lock out hoist movement until load has been unhooked.
- Always leave bottom hook and pendant controls in a vertical, static position, never in a position that can produce swing or slip.

12.3 Load Brake Function

The mechanical load brake holds a full capacity load independent of the motor brake, and prevents load from accelerating during lowering process.

12.4 Overload Protection

The BLVS hoist is equipped with an overload protection sensor that monitors current, voltage and

temperature inside the hoist. If current exceeds 15A, voltage drops below 100V, and/or internal temperature exceeds 160°F (75°C), the motor will continue to function but at decreased speed.

13.0 Adjustments

13.1 Replacing Load Chain

Over time, the load chain will wear or elongate. This can cause damage to hoist, breakage, or non-engagement of the load sheave. The following procedures describe replacing the load chain for single and multiple fall hoists. **These procedures must be performed by qualified persons only.**

It is recommended that after installing new chain, the first few lifts be limited to no more than 25-50% of rated load capacity. Thoroughly inspect new chain for twist before placing hoist into routine service.

IMPORTANT: Due to the internal space of hoist, additional length must be added to the nominal chain length, as shown in Table 4. For example, model BLVS018 with 10 ft. lift requires 10.66 ft. of chain.

Model	Additional length of chain
BLVS018	0.66 ft.
BLVS025	0.66 ft.
BLVS050	1.32 ft.
BLVS100	1.65 ft.
BLVS200	3.3 ft.

Table 4

13.1.1 Cutting Chain

WARNING Use eye/face protection when cutting chain.

Use a bolt cutter with special cutter jaws for cutting hardened chain. Cut only one side of the link at a time. When making the second cut, place a mat over the chain to catch the flying chain section.

(Note that the following Figures may or may not show your particular hoist model, but the procedure is identical.)

13.1.2 Single Fall Chain Hoist

- Locate the flexible chain puller that was provided with your hoist.
- Lower the load hook until only 1 to 2 feet of slack chain remains in the chain container.
- Remove chain container.
- On the slack side of the chain, remove the chain stop, spring, and plates (Figure 13-1). Keep these handy for later re-installing.

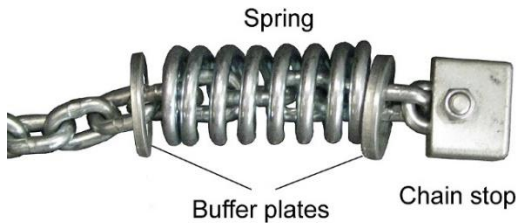

Figure 13-1

5. Keep tension on chain and press DOWN on controller until slack end of old chain comes free of the hoist.
6. Insert chain puller through hoist as shown in Figure 13-2.
7. Connect hook of chain puller to the link on new chain (Figure 13-3), and pull chain through until it engages the sprocket. **Do not let the chain twist or bind as it is being pulled through the hoist.**

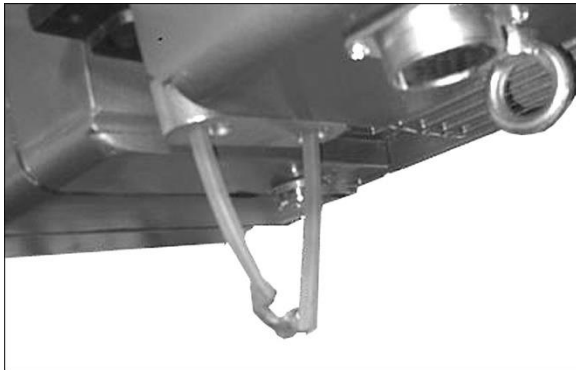

Figure 13-2

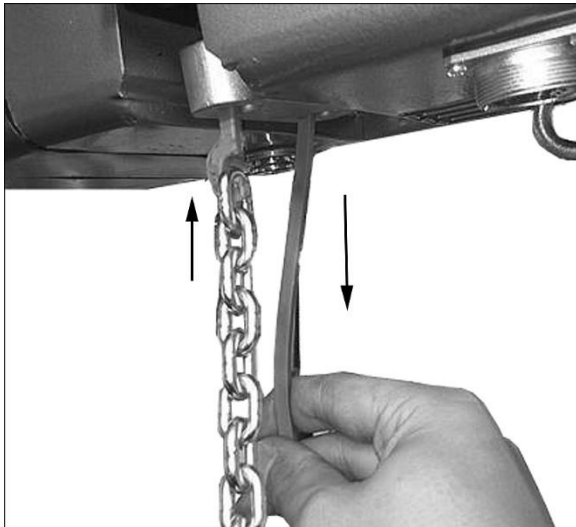

Figure 13-3

8. Keep tension on the end of the new chain and press the DOWN button on the controller, until chain clears the hoist. Stop hoist when 1 to 2 feet of new chain remains on the slack side.
9. Install the chain stop, spring and plates (Figure 13-1) on the slack end of the chain.

10. Install chain container, making sure to install the self-locking nut on the screw. *Do not fill chain container by hand.*
11. Remove load hook from old chain and install on new chain end.
12. Test limit switches by raising and lowering hook. Inspect chain for any signs of twist or binding, and correct before continuing.
13. Lubricate new chain with light coat of oil.

13.1.3 Vertical and Horizontal Links

Vertical and horizontal are determined by the relationship to the load chain sheave. Vertical links will be guided by the center slit in the sheave. Horizontal links will engage the oval pockets on the sheave. See Figure 13-4.

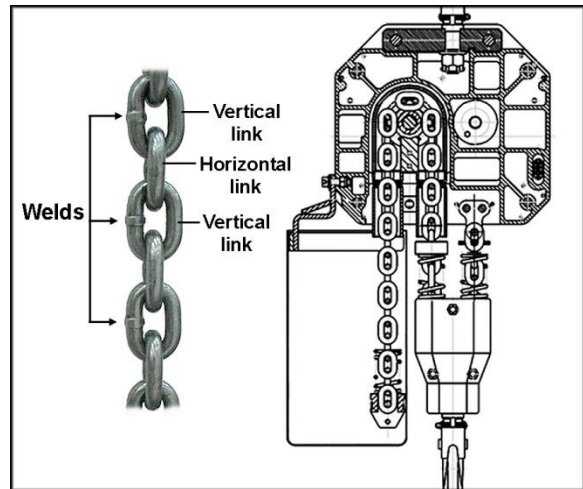

Figure 13-4

13.1.4 Double Fall Chain Hoists

CAUTION The link on the load side end must be a vertical link. If it is a horizontal link, the chain will have a twist in it.

1. Locate the flexible chain puller that was provided with your hoist.
2. Lower the load hook until only 1 to 2 feet of slack chain remains in the chain container.
3. Remove chain container.
4. On the slack end of the chain, remove the chain stop, spring, and plates (Figure 13-1). Keep these handy for later re-installing.
5. Keep tension on chain and press DOWN on controller until slack end of old chain comes free of the hoist.
6. Insert chain puller through hoist as shown in Figure 13-2.
7. Connect hook of chain puller to the link on new chain (Figure 13-3) and move chain through until sprockets are engaged.

⚠CAUTION The link on the load side end must be a vertical link, as shown in Figure 13-3. If it is a horizontal link, the chain will have a twist in it.

8. Press DOWN on controller while pulling chain through until it completely engages the sprocket and emerges from other side. Do not let the chain twist or bind as it is being pulled through the hoist.
9. Keep tension on the end of the new chain and press DOWN on the controller, until 1 to 2 feet of new chain remains on the slack side.
10. Install the chain stop, spring, and plates (Figure 13-1) on the slack end of the chain.
11. Install chain container, making sure to install the self-locking nut on the screw. *Do not fill chain container by hand.*
12. Press UP button to further lower some of the slack end of chain into container, while keeping light tension on the load end of chain.

13. Attach the load hook using the chain puller, as shown in Figure 13-5.
14. Attach the load end of chain to the connecting pin on the hoist. Make sure the chain does not twist to accommodate the pin.
15. Test limit switches by raising and lowering hook. Inspect chain for any signs of twist or binding, and correct before continuing.



Figure 13-5

14.0 Transmitter/Receiver Synchronization

Copy from Original Transmitter to New Transmitter

1. Turn OFF both transmitters *at the same time* by pushing the E-stops.
2. On original transmitter, Press UP button then press DOWN button. Repeat this 3 more times.
3. Status light will blink red and green.
4. Press and hold UP button until the “1” and “2” lights are blinking rapidly.
5. Release UP button.



ORIGINAL

6. On new transmitter, Press UP then press DOWN. Repeat this 3 more times.
7. Status light will blink red and green.
8. Press and hold DOWN button until the “1” and “2” lights blink and then go dark.
9. Process complete.



NEW

Note: 2 controllers may share the same signal but only one can turn on to control the hoist.

Copy from Receiver to New Transmitter

1. Remove hoist cover which has the antenna.
2. Connect power to hoist. **WARNING: Electrical voltage.**
3. Press and hold SYNC button until status light on the PC board blinks red and green.

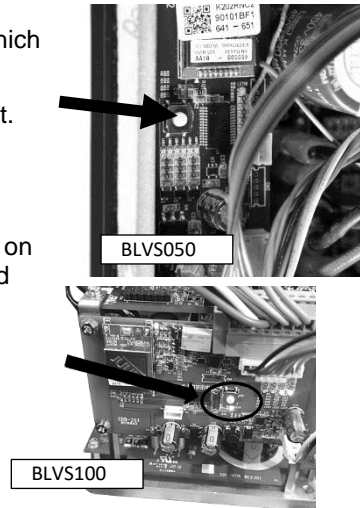

4. Press E-stop button.
5. Press UP button then DOWN button. Repeat this 3 more times.
6. Status light will blink green and red.
7. Press and hold DOWN button until the “1” and “2” lights blink. Release DOWN button.
8. Wait until all lights “1” thru “4” blink in sequence.
9. Process complete.



NEW

Copy from Transmitter to New Receiver

1. Remove hoist cover which has the antenna.
2. Connect power to hoist. **WARNING: Electrical voltage.**
3. Press and hold SYNC button until status light on the PC board blinks red and green.

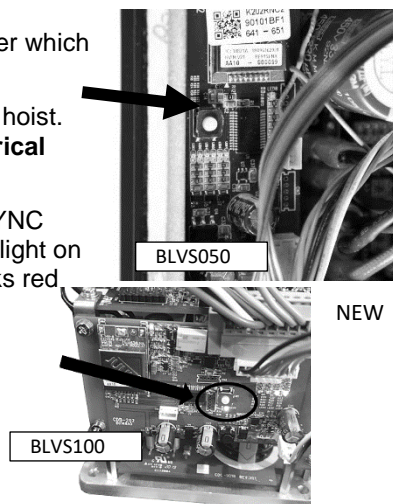

NEW

4. Press E-stop button.
5. Press UP button then DOWN button. Repeat this 3 more times.
6. Status light will blink red and green.
7. Press and hold DOWN button until the “1” and “2” lights blink. Release DOWN button.
8. Wait until all lights “1” thru “4” blink in sequence.
9. Process complete.



ORIGINAL

15.0 Mechanical Classification (Grade)

The JET BLVS-series hoists have been designed for **grade 1Am** in the FEM regulations (FEM 9.5.11). See Table 5.

The life and safety of the electric hoist can only be guaranteed when the equipment is operated within its prescribed grade.

Average daily operating time and total operating time are determined by load distribution.

Load Spectrum (Load distribution)	Definitions	Cubic mean value	Average daily Operation time (hours)	Total operating time (hours)
1 (light)	Mechanisms or parts thereof, usually subject to very small loads and in exceptional cases only to maximum loads.	$k \leq 0.50$	2-4	6300
2 (medium)	Mechanisms or parts thereof, usually subject to small loads but rather often to maximum loads.	$0.50 < k \leq 0.63$	1-2	3200
3 (heavy)	Mechanisms or parts thereof, usually subject to medium loads but frequently to maximum loads.	$0.63 < k \leq 0.80$	0.5-1	1600
4 (very heavy)	Mechanisms or parts thereof, usually subject to maximum or almost maximum loads.	$0.80 < k \leq 1.00$	0.25-0.5	800

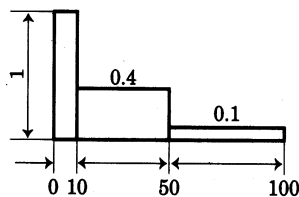

% operating time
Load spectrum 1

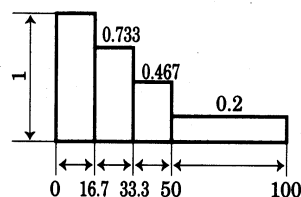

% operating time
Load spectrum 2

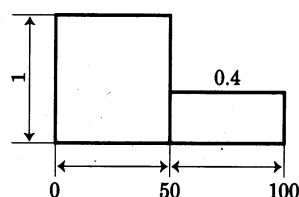

% operating time
Load spectrum 3

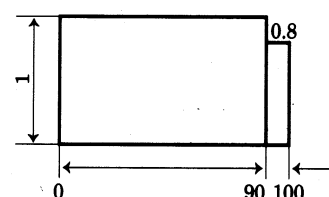

% operating time
Load spectrum 4

Table 5

16.0 Inspection and Maintenance

⚠WARNING All repairs and adjustments are to be performed by qualified persons using procedures that are approved for the hoist system being serviced. All safety-related deficiencies discovered in the inspection are to be corrected before hoist is placed back into service. Check for internal damage whenever external damage has occurred.

Appropriate LOCK OUT/TAG OUT procedures must be followed when performing maintenance.

Read and follow all relevant ANSI Inspection and Maintenance standards, particularly ANSI/ASME B30.16 *Overhead Hoists (Underhung)*. Know the meaning of Frequent Inspection, Periodic Inspection, Normal Service, Heavy Service, and Severe Service. It is the customer's responsibility to understand and follow all ANSI and JET inspection and maintenance instructions.

The following definitions are based upon ANSI/ASME B30.16.

Normal Service: Operation with randomly distributed loads within the rated load limit or uniform loads less than 65% of rated load for not more than 25% of the time.

Heavy Service: Operation within rated load limit, which exceeds normal service.

Severe Service: Normal or heavy service with abnormal operating conditions.

Designated Person: A person selected or assigned as being competent to perform the specific duties to which he/she is assigned.

Qualified Person: A person who, by a recognized degree or certificate of professional standing, or who, by extensive knowledge, training, and experience, has successfully demonstrated the ability to solve or resolve problems relating to the subject matter and work.

16.1 Gearbox Oil

The oil in the gearbox should be changed annually, or more frequently under severe service, as follows.

Use either of these recommended oil brands, or their equivalent:

ISO-VGDIN 51519 Viscosity at 40°C mm ² /s (cST)	Approximate Viscosity of the VG Categories 50°C mm ² /s (cST)	ARAL	BP	ESSO	MOBIL OIL	SHELL	TEXACO	IP	AGIP
VG460	251	Degol BG 460 - BMB 460	Energol GR-XP 460	Spartan EP-460	Mobilgear 634	Omala Oil 460	Meropa 460	Mellana 460	Blasia 460

Table 6

To drain and refill gearbox:

1. Open fill plug on top of hoist.
2. Open drain plug underneath hoist and drain reservoir. Reinstall drain plug.
3. Check gearbox oil capacity for your model hoist, according to *sect. 7.0*.
4. Pour oil into fill hole.
5. Reinstall top plug.
6. Dispose of used oil according to local regulations.

17.0 Inspection Schedules

The TS series Hoist should be given an **initial inspection** upon installation and prior to use (see also *Pre-Operation Inspection* in this manual). Following that, it must be inspected by a designated person at the time interval noted below. Dated inspection and repair reports must be maintained. Copies of all reports must be available to service personnel.

Visual inspections are divided into two general classifications based upon frequency, then further categorized by type of service, as shown below.

More detailed information may be found in ANSI/ASME B30.16 standards publication.

FREQUENT Inspection Schedule

Service Interval:

Normal Service: Monthly

Heavy Service: Weekly

Severe Service: Daily

1. Check oil level in gearbox.
2. Check braking system for slippage.
3. Check that pushbutton controls and emergency stop operate properly.
4. Check that limit switches function properly. Without load, operate UP button control while observing limit spring. If limit spring becomes compressed and motor does not stop, STOP operation immediately. Limit switch is not operating properly. Repeat test with DOWN button control.
5. Check top hook and load hook for deformation, chemical damage, and cracks.
6. Check hook latch operation.
7. Check that load chain is clean and lightly lubricated, free of excessive wear or deformation at the contact points between links and link and hook (see *section 17.0* in this manual). This hoist uses special alloy hoisting chain and does not interchange with any other manufacturer. All replacement chain must be purchased from your JET distributor or from JET directly by calling 800-274-6848.
8. Check that the chain passes smoothly through all sprockets while under load.
9. Check entire hoist system for signs of damage and loss of integrity. Listen for any abnormal sounds.

PERIODIC Inspection Schedule

Service Interval:

Normal Service: Yearly

Heavy Service: Semi-Annually

Severe Service: Quarterly

1. Perform all of the Frequent Inspection items.
2. Drain and refill gearbox. (See *section 10.2.1* for details and capacities.)
3. Check entire unit for loose screws, bolts, nuts, rivets and pins.
4. Check for evidence of excessive wear, corrosion, cracks, or distortion in the following parts: hook parts, chain attachments, suspension bolts and shafts, housings, gears, bearings, pins, rollers, and locking and clamping devices.
5. Check for evidence of damage to hook parts including hook retaining nuts and collars and pins, and hook holding frame and parts used to secure the frame.
6. Check for evidence of damage or excessive wear of load gear, sheave and sprocket wheel. If the pockets are too deep, the chain may jam with corresponding failure of engagement between chain and sprocket or sheave.
7. Check for evidence of excessive load brake wear. Inspect clearance between brake components, and adjust if needed.
8. Check for evidence of pitting or other deterioration of visible controller contacts.
9. Check for evidence of deterioration of supporting structures and trolleys.
10. Check for visible deformation of limit switch coil springs.
11. Check that all warning labels are present and legible.

18.0 Allowable Limits

18.1 Hook Wear Limits (Top and Bottom)

Replace a hook if wear or deformation exceeds 5% of the measurements in Table 7. Never heat-treat the hook or attach anything to the hook by welding.

NOTE: Excessive hook throat opening or twist indicates abuse or overloading of the hoist. If such deformation is discovered, inspect the hoist, chain and all supporting members very carefully for additional indications of excessive hoist loading.

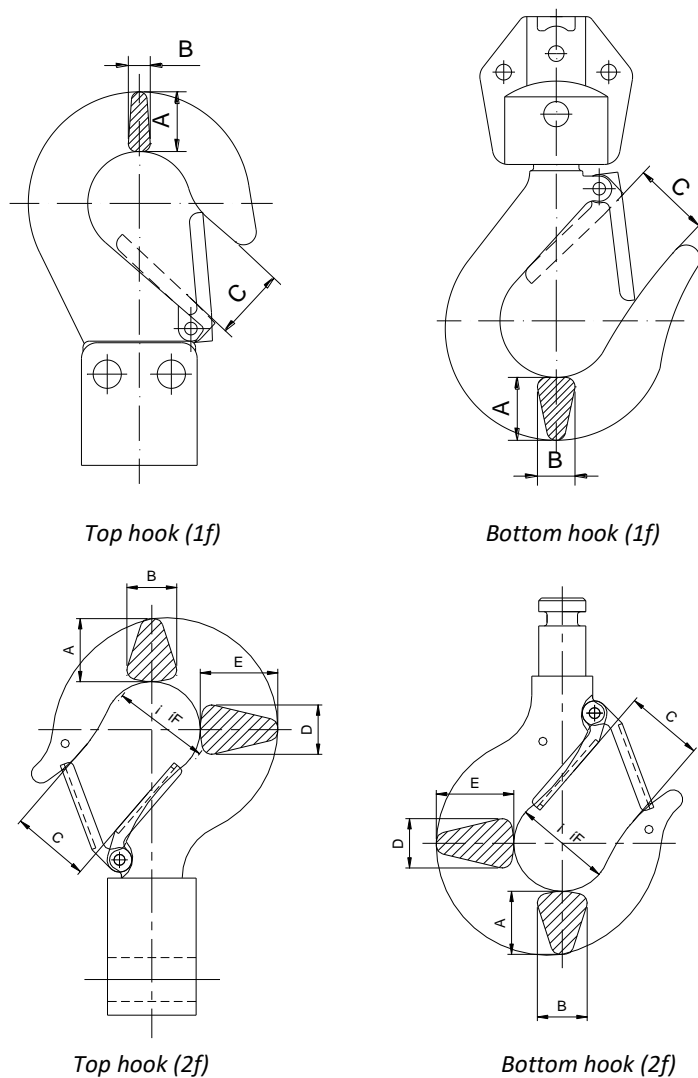

Figure 16-1

Fall	Hook	Dimensions (mm)					
		A	B	C	D	E	F
1f	Top hook	19	7	22			
	Bottom hook	20	12	24			
2f	Top hook	23	18	28	18	28	34
	Bottom hook	23	18	28	18	28	34

T = top hook; B = bottom hook

Table 7

18.2 Chain Wear Limits

Carefully inspect the entire load chain each month. Measure each link with the provided chain gauge. See Figures 16-4 and 16-5. Any load chain that shows noticeable deformation or heat influence must be replaced with a new one. Never extend load chain by welding a second piece to the original.

The load sheave and chain regulator must also be inspected, as any wear or damage to the chain will be transmitted to these parts also.

Any replacement of chain and sheave elements must be done by qualified persons only.

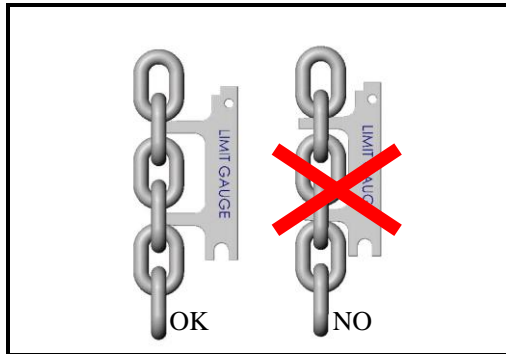

Figure 16-4: pitch

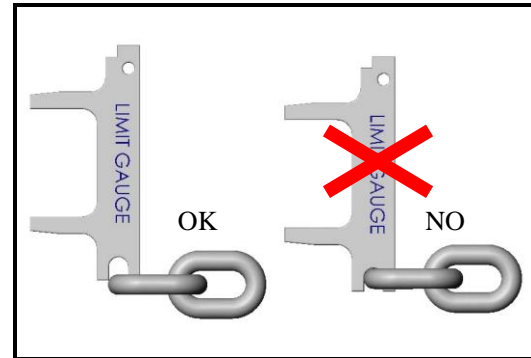
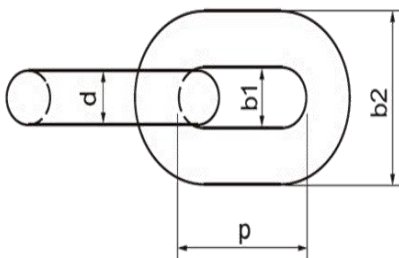

Figure 16-5: diameter



Model	Diameter (mm) (d)	Inside Length (mm) (p)	Inside Width (mm) (b1)	Outside Width (mm) (b2)	Breaking Load (kN)
BLVS -018, -025, -050	4	12	5	13.6	20.1
BLVS -100, -200	7.1	20.2	8.4	23.6	63

Figure 16-6

19.0 Chain Container Selection for BLVS Series Hoist

If chain length is ever increased, make sure proper chain container is installed.

Hoist tonnage	Model	Lift (feet)									
		10	20	30	40	50	60	70	80	90	100
1/8	BLVS018	-01	-01								
1/4	BLVS025	-01	-01	-02	-02	-03	-03	-03	-04	-04	-04
1/2	BLVS050	-01	-01	-02	-02	-03	-03	-03	-04	-04	-04
1	BLVS100	-01-1	-01-1	-02-1	-02-1	-03-1	-03-1	-04-1	-04-1		
2	BLVS200	-01-1	-02-1	-03-1	-04-1						

Table 8

Container part numbers:

BLVS-CC-01 (polyethylene)
BLVS-CC-02 (polyethylene)
BLVS-CC-03 (canvas)
BLVS-CC-04 (canvas)
BLVS-CC-01-1 (canvas)
BLVS-CC-02-1 (canvas)
BLVS-CC-03-1 (canvas)
BLVS-CC-04-1 (canvas)

20.0 Controllers for BLVS Hoists

Part no.	Description
140192	Wireless Controller, for all models (provided with hoist)
104063	Wired Pendant, 2-BTN, for 10ft Hoist
104064	Wired Pendant, 2-BTN, for 15ft Hoist
104065	Wired Pendant, 2-BTN, for 20ft Hoist

Table 9

21.0 Troubleshooting BLVS Series Hoists

Important: Any servicing performed on the brake or other electrical components must be done by qualified persons only. Further information on the remote controller may be found in its accompanying manual.

Trouble	Probable Cause	Suggested Remedy
Hoist will not respond to controls.	Limit switch is tripped.	Move hook in opposite direction. If limit switches need adjustment, have qualified person inspect them.
	Hoist overloaded.	Reduce load to within rated capacity.
	No incoming power, or low voltage.	Check hoist connections to power source. If low voltage, have certified electrician check incoming power.
	Fuse blown or circuit breaker tripped.	Replace fuse/re-set circuit breaker.
	Broken wire to control pendant.	Locate and repair.
	Incorrect phasing.	Switch any two of the three supply wires.
	Brake won't release; or rectifier damaged in the phase protector.	Inspect continuity in brake; replace phase protector.
	Control contacts not opening/closing properly.	Check electrical continuity; replace any defective parts.
	Faulty contactor.	Operate hoist manually; if successful, then control circuit is faulty – locate and repair. If hoist still does not run check main supply. If input supply is correct but output supply is faulty, replace contactor.
Motor malfunction.	Have motor inspected by a qualified service technician; repair or replace as needed.	
Hoist operates only intermittently.	Loose connectors; poor contacts; arcing.	Inspect all wiring and contacts.
	Broken conductor in control cord	Test continuity of each conductor. Replace cable if needed.
Hoist refuses to stop.	Welded contacts in contactor.	Replace contactor.
Hoist lifts but will not lower.	Broken conductor in control cord.	Test continuity of each conductor. Replace cable if needed.
	Up/down switch malfunctioning.	Repair or replace switch.
Hoist lowers but will not lift.	Hoist overloaded.	Reduce load to within rated capacity.
	Up/down switch malfunction.	Repair or replace switch.
Load continues drifting down excessively when hoist is stopped.	Hoist overloaded.	Reduce load to within rated capacity.
	Brake out of adjustment.	Adjust brake air gap. Replace brake lining if worn.
	Grease or oil on the lining.	Open hoist, disassemble brake and clean the lining (qualified persons only).
	Brake springs are damaged.	Replace brake springs.
Hoist moves in wrong direction.	Incorrect phasing (230V model).	Switch any two of the three supply wires
Motor overheats.	Excessive load or too frequent use; or affected by ambient temperature	Operate within rated load and according to duty cycle rating. Limit use of hoist in ambient temperatures over 104°.
Poor engagement of chain with sprocket/sheave.	Load chain is considerably worn.	Replace load chain.
	Sprocket wheel, sheave or chain guide is considerably worn.	Replace parts as needed.
Limit switch failure.	Bad connection of limit switch leads.	Inspect contacts of leads and limit switches.
	Limit switch damaged.	Replace.
Abnormal sounds.	Brake out of adjustment.	Inspect and adjust/repair as needed.
	Dry chain or worn sprocket	Lubricate or replace as needed.

Table 10

22.0 Replacement Parts

Replacement parts are listed on the following pages. To order parts or reach our service department, call 1-800-274-6848 Monday through Friday, 8:00 a.m. to 5:00 p.m. CST. Having the Model Number and Serial Number of your machine available when you call will allow us to serve you quickly and accurately.

Non-proprietary parts, such as fasteners, can be found at local hardware stores, or may be ordered from JET.

Some parts are shown for reference only, and may not be available individually.

NOTE: If an item shows two part numbers, the hoist model on which it is used can be identified by the part number.

22.1.1 BLVS018 and BLVS025 Hoists – Exploded View

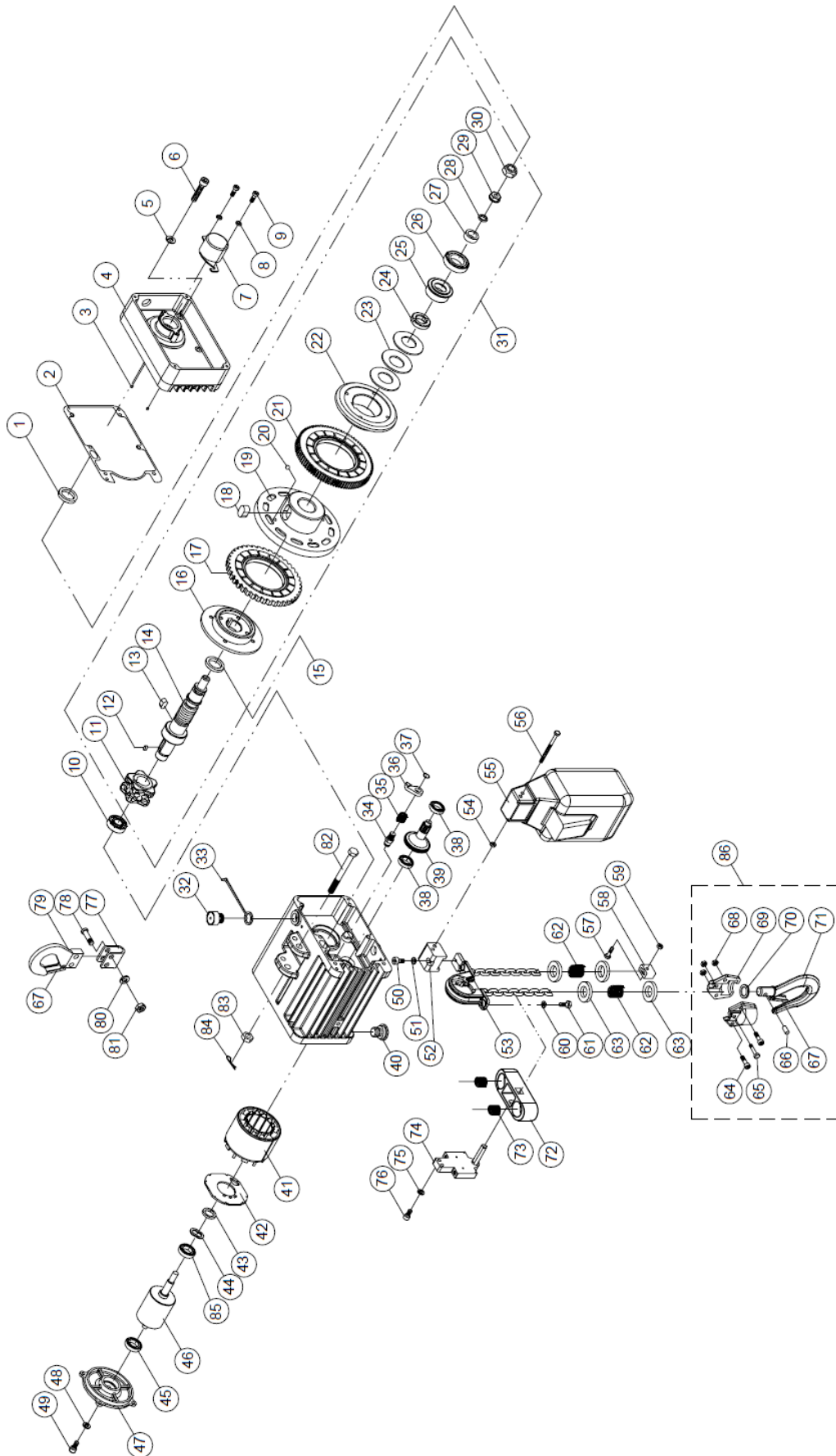

22.1.2 BLVS018 and BLVS025 – Parts List

Index No.	Part No.	Description	Size	Qty
1	BLVS018-A01	Oil Seal	Ø25xØ35x5t	1
2	BLVS018-A02	Gasket	#40	1
3	BLVS018-A03	Parallel Pin	Ø5x12L	2
4	BLVS018-A04	Gearbox		1
5	TS-2361061	Spring Washer	M6	6
6	TS-1503071	Socket Hd Cap Screw	M6x1.0x30L	6
7	BLVS018-A07	Cover		1
8	TS-1550021	Flat Washer	M4	2
9	TS-2171012	Phillips Pan Hd Mach Screw	M4x0.7x6L	2
10	BB-6202ZZ	Bearing	6202 ZZ	1
11	BLVS018-A11	Load Sheave		1
12	BLVS018-A12	Key	t5x5x20L	1
13	BLVS018-A13	Key	t6x6x12L	1
14	BLVS018-A14	Sheave Spindle	Ø30x145L	1
15	BLVS018-A15	Oil Seal	Ø30xØ50x8t	1
16	BLVS018-A16	Brake Body	Ø83xØ20x17.5L	1
17	BLVS018-A17	Ratchet Assembly		1
18	BLVS018-A18	Key	t10x8x16L	1
19	BLVS018-A19	Brake Bushing	Ø105x27.75L	1
20	SB-6M	Steel Ball	Ø6	3
21	BLVS018-A21	4th Gear Assembly	M1.25x89T	1
22	BLVS018-A22	Brake Flange	Ø87x19.1L	1
23	BLVS018-A23	Disc Spring		3
	BLVS025-A23			-
24	BLVS018-A24	Load Brake Gear Spacer		2
25	BLVS018-A25	Bushing	Ø34x10L	1
26	BB-6003	Bearing	6003	1
27	BLVS018-A27	Oil Bushing	Ø25xØ17x9L	1
28	BLVS018-A28	O-Ring	Ø12xØ17x2.5	1
29	BLVS018-A29	Flange Nut	M10x1.5x8L	1
30	TS-2361101	Lock Nut	M10x1.5	1
31	BLVS018-A31	Over Load Assembly		1
	BLVS025-A31			
32	BLVS018-A32	Hex. Oil Plug		1
33	BLVS018-A33	Breather Plug		1
34	BLVS018-A34	Ratchet Pawl Pin	d14x26L	2
35	BLVS018-A35	Ratchet Pawl Spring		2
36	BLVS018-A36	Ratchet Pawl		2
37	F006098	C-Retaining Ring, Ext	S-11	2
38	BB-6000	Bearing	6000	2
39	BLVS018-A39	2nd & 3rd Gear Set		1
40	BLVS018-A40	Oil plug		1
41	BLVS018-A41	Stator Assembly	300W	1
	BLVS025-A41	Stator Assembly	600W	1
42	BLVS018-A42	Hall Sensor Plate		1
43	BLVS018-A43	Oil Seal	Ø12xØ25x7t	1
44	BLVS018-A44	Wave Washer	31x23.2x0.3t	1
45	BB-6201ZZ	Bearing	6201ZZ	1
46	BLVS018-A46	Rotor	300W	1
	BLVS025-A46	Rotor	600W	1
47	BLVS018-A47	Motor End Cover		1
48	TS-2361051	Spring Washer	M5	4
49	TS-1502041	Socket Hd Cap Screw	M5x0.8x16L	4
50	TS-1502021	Socket Hd Cap Screw	M5x0.8x10L	1
51	TS-2361051	Spring Washer	M5	1
52	BLVS018-A52	Chain Bucket Connector		1
53	BLVS018-A53	Chain Guide		1
	LCHAIN-4x12	Load Chain	4.0x12mm	per ft.
	BLVS018-A54	Chain Puller (not shown)	4.0x12mm	1

Index No.	Part No.	Description	Size	Qty
54	TS-1541011	Lock Nut	M5	2
55	(see sect. 19.0)	Chain Container		1
56	BLVS018-A56	Socket Hd Cap Screw	M5x0.8x70L	2
57	BLVS018-A57	Lock Pin	Ø10x25.5L	1
58	BLVS018-A58	Chain Stopper	24x19x13.5	1
59	TS-1541011	Lock Nut	M5	1
60	TS-2361061	Spring Washer	M6	2
61	TS-1503041	Socket Hd Cap Screw	M6x1.0x16L	2
62	BLVS018-A62	Spring		2
63	BLVS018-A63	Buffer Steel Plate	Ø25.5xØ14xt4	4
64	TS-1502051	Socket Hd Cap Screw	M5x0.8x20L	2
65	BLVS018-A65	Lock Pin	Ø10x25.5L	1
66	BLVS018-A66	Parallel Pin	Ø8x25L	1
67	BLVS018-A67	Safety Latch Assembly		2
68	TS-1541011	Lock Nut	M5	3
69	BLVS018-A69	Bottom Hook Cover Set		2
70	BLVS018-A70	Thrust Bearing		1
71	BLVS018-A71	Bottom Hook		1
72	BLVS018-A72	Collision Block		1
73	BLVS018-A73	Collision Block Spring		2
74	BLVS018-A74	Limit Switch Assembly		1
75	TS-2361051	Spring Washer	M5	2
76	TS-1502051	Socket Hd Cap Screw	M5x0.8x20L	2
77	BLVS018-A77	Top Hook Suspension	t20x37x39L	1
78	BLVS018-A78	Top Hook Lock Bolt	Ø12x29.5L	2
79	BLVS018-A79	Top Hook		1
80	TS-2361081	Spring Washer	M8	2
81	TS-1541031	Lock Nut	M8x1.25	2
82	BLVS018-A82	Lock Bolt	Ø12/M12x1.75x85L	1
83	TS-2342121	Hex. Nut	M12x1.75	1
84	BLVS018-A84	Cotter Pin	Ø3x30L	1
85	BLVS018-A85	Bearing	62012RS	1
86	BLVS018-A86	Bottom Hook Assembly		1

22.2.1 BLVS050 Hoist – Parts List

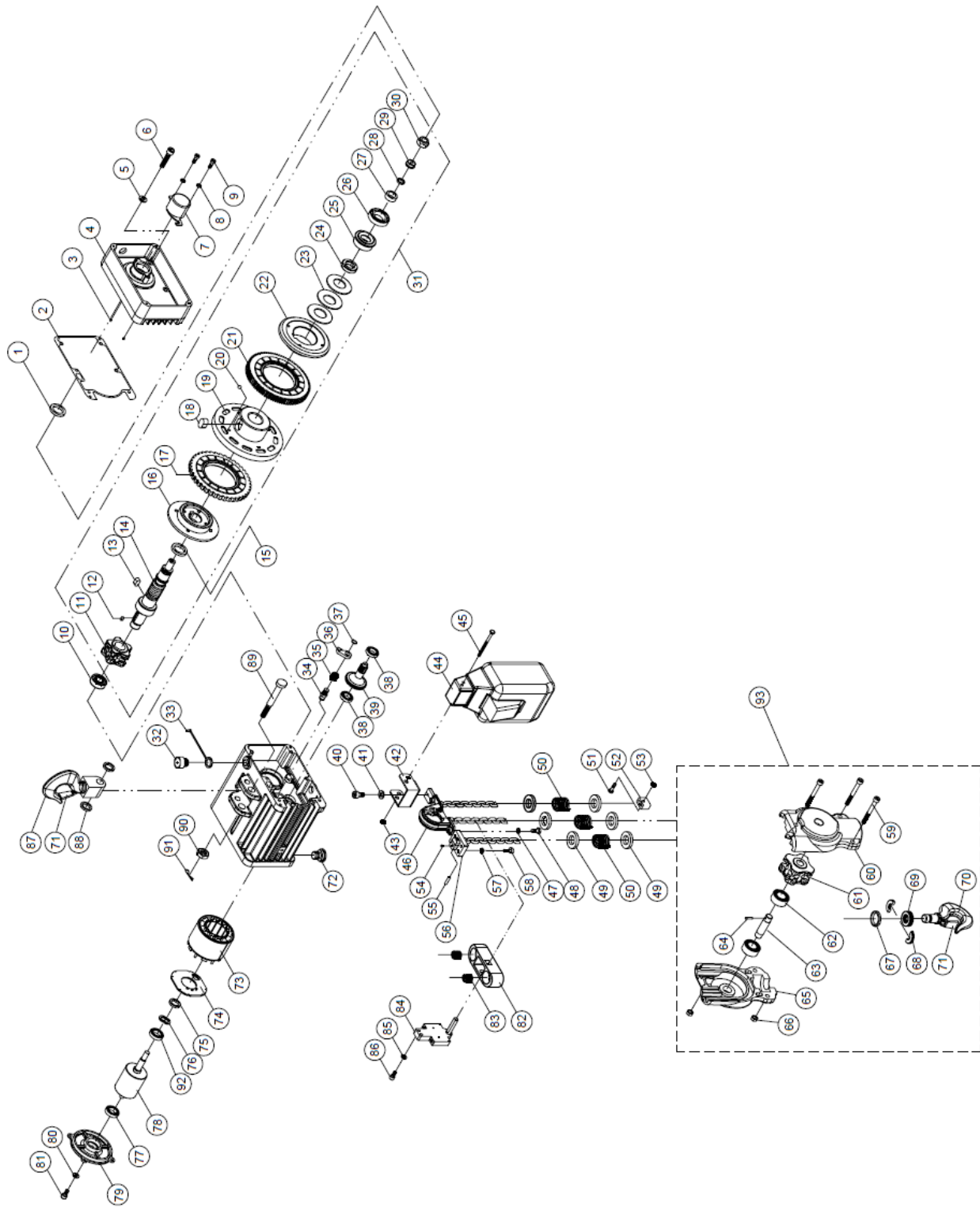

22.2.2 BLVS050 Hoist – Parts List

Index No.	Part No.	Description	Size	Qty
1	BLVS018-A01	Oil Seal	Ø25xØ35x5t	1
2	BLVS018-A02	Gasket	#40	1
3	BLVS018-A03	Parallel Pin	Ø5x12	2
4	BLVS018-A04	Gearbox		1
5	TS-2361061	Spring Washer	M6	6
6	TS-1503071	Socket Hd Cap Screw	M6x1.0x30L	6
7	BLVS018-A07	Cover		1
8	TS-1550021	Flat Washer	M4	2
9	TS-2171012	Phillips Pan Hd Mach Screw	M4x0.7x6L	2
10	BB-6202ZZ	Bearing	6202ZZ	1
11	BLVS018-A11	Load Sheave		1
12	BLVS018-A12	Key	t5x5x20L	1
13	BLVS018-A13	Key	t6x6x12L	1
14	BLVS018-A14	Sheave Spindle	Ø30x145L	1
15	BLVS018-A15	Oil Seal	Ø30xØ50x8t	1
16	BLVS018-A16	Brake Body	Ø83xØ20x17.5L	1
17	BLVS018-A17	Ratchet Assembly		1
18	BLVS018-A18	Key	t10x8x16L	1
19	BLVS018-A19	Brake Bushing	Ø105x27.75L	1
20	SB-6MM	Steel Ball	Ø6	3
21	BLVS018-A21	4th Gear Assembly	M1.25x89T	1
22	BLVS018-A22	Brake Flange	Ø87x19.1L	1
23	BLVS050-A23	Disc Spring		3
24	BLVS050-A24	Load Brake Gear Spacer		2
25	BLVS050-A25	Bushing	Ø34x10L	1
26	BB-6003	Bearing	6003	1
27	BLVS018-A27	Oil Bushing	Ø25xØ 17x9L	1
28	BLVS018-A28	O-Ring	Ø12xØ17x2.5	1
29	BLVS018-A29	Flange Nut	M10x1.5x8L	1
30	TS-2342101	Lock Nut	M10x1.5	1
31	BLVS018-A31	Over Load Assembly		1
32	BLVS018-A32	Hex. Oil Plug		1
33	BLVS018-A33	Breather Plug		1
34	BLVS018-A34	Ratchet Pawl Pin	d14x26L	2
35	BLVS018-A35	Ratchet Pawl Spring		2
36	BLVS018-A36	Ratchet Pawl		2
37	F006098	C-Retaining Ring, Ext	S-11	2
38	BB-6000	Bearing	6000	2
39	BLVS018-A39	2nd & 3rd Gear Set		1
40	TS-1502021	Socket Hd Cap Screw	M5x0.8x10L	1
41	TS-2361051	Spring Washer	M5	1
42	BLVS018-A52	Chain Bucket Connector		1
43	TS-1541011	Lock Nut	M5	2
44	(see sect. 19.0)	Chain Container		1
	LCHAIN-4x12	Load Chain	4.0x12mm	per ft.
	BLVS018-A54	Chain Puller (not shown)	4.0x12mm	1
45	BLVS018-A56	Socket Hd Cap Screw	M5x0.8x70L	2
46	BLVS018-A53	Chain Guide		1
47	TS-2361061	Spring Washer	M6	2
48	TS-1503041	Hex. Recess Bolt	M6x1.0x16L	2
49	BLVS018-A63	Buffer Steel Plate	Ø25.5xØ 14xt4	6
50	BLVS018-A62	Spring		3
51	BLVS018-A65	Lock Pin	Ø10x25.5L	1
52	BLVS018-A58	Chain Stopper	24x19x13.5	1
53	TS-1541011	Lock Nut	M5	1
54	BLVS050-A54	Threaded Stud	M4x0.7x4L	1
55	BLVS050-A55	Parallel Pin	Ø5x25L	1
56	BLVS050-A56	Load Bracket		1
57	TS-2361051	Spring Washer	M5	4
58	TS-1502041	Socket Hd Cap Screw	M5x0.8x15L	4

Index No.	Part No.	Description	Size	Qty
59	TS-1502051	Socket Hd Cap Screw	M5x0.8x20L	3
60	BLVS050-A60	Bottom Block Cover A		1
61	BLVS050-A61	Sprocket		1
62	BLVS050-A62	Needle Bearing	HK1412	2
63	BLVS050-A63	Sprocket Axle		1
64	BLVS050-A64	Spring Pin	Ø3x10L	1
65	BLVS050-A65	Bottom Block Cover B		1
66	TS-1541011	Nylon Nut	M5	3
67	BLVS050-A67	End Spacer		1
68	BLVS050-A68	Half Spacer		2
69	BB-51103	Thrust Bearing	51103	1
70	BLVS050-A70	Bottom Hook		1
71	BLVS050-A71	Safety Latch Assembly		2
72	BLVS018-A40	Oil plug		1
73	BLVS025-A41	Stator Assembly	600W	1
74	BLVS018-A42	Hall Sensor Plate		1
75	BLVS018-A43	Oil Seal	Ø12xØ25x7t	1
76	BLVS018-A44	Wave Washer	31x23.2x0.3t	1
77	BB-6201ZZ	Bearing	6201ZZ	1
78	BLVS025-A46	Rotor	600W	1
79	BLVS018-A47	Motor End Cover		1
80	TS-2361051	Spring Washer	M5	4
81	TS-1502041	Socket Hd Cap Screw	M5x0.8x16L	4
82	BLVS018-A72	Collision Block		1
83	BLVS018-A73	Collision Block Spring		2
84	BLVS018-A74	Limit Switch Assembly		1
85	TS-2361051	Spring Washer	M5	2
86	TS-1502051	Socket Hd Cap Screw	M5x0.8x20L	2
87	BLVS050-A87	Top Hook Assembly		1
88	BLVS050-A88	Washer		2
89	BLVS050-A89	Lock Bolt	Ø15/M12x1.75x85L	1
90	TS-1540081	Hex. Nut	M12x1.75	1
91	BLVS018-A84	Cotter Pin	Ø3x30L	1
92	BB-62012RS	Bearing	6201 2RS	1
93	BLVS050-A93	Bottom Hook Assembly		1

22.3.1 BLVS018, 025, 050 Hoist – Exploded View II

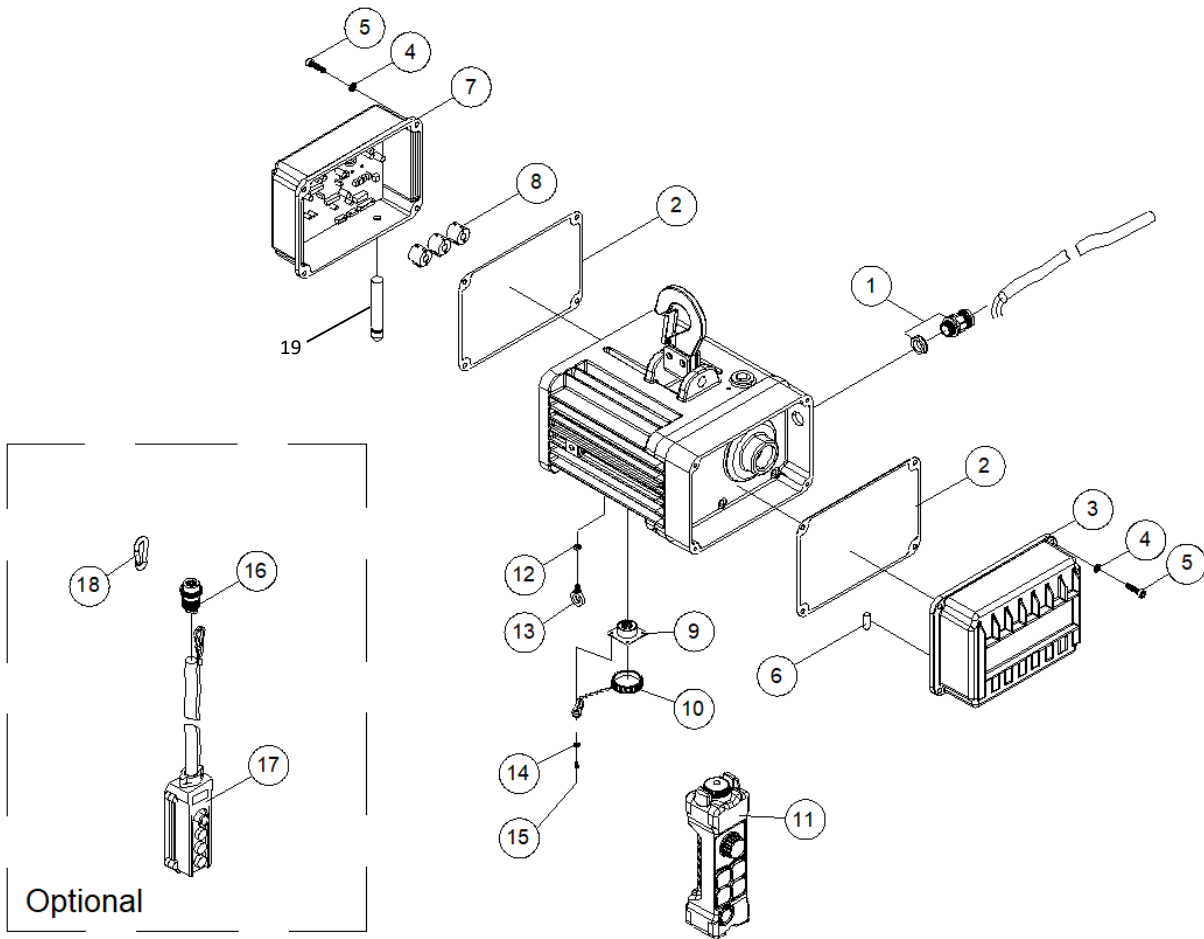

22.3.2 BLVS018, 025, 050 Hoist – Parts List II

Index No.	Part No.	Description	Size	Qty
1	BLVS018-B01	Cable Gland	M16	1
2	BLVS018-B02	Gasket	#41	2
	BLVS018-B03A	PFC Power Supply Assembly (includes #3 and #7)		1
3	BLVS018-B03	PFC Power Supply Assembly (RE: BLVS018-B03A)		1
4	TS-2361051	Spring Washer	M5	8
5	TS-1502041	Socket Hd Cap Screw	M5x0.8x16L	8
6	BLVS018-B06	Fuse	6x30-20A	1
7	BLVS018-B07	DC Motor Controller Assembly (RE: BLVS018-B03A)		1
8	BLVS018-B08	Magnetic Clip		3
9	BLVS018-B09	Female Receptacle		1
10	BLVS018-B10	Metal Dust Cap		1
11	140192	Wireless Controller		1
12	TS-1540041	Nut	M6x1.0	1
13	BLVS018-B13	Eye Bolt	M6x1.0	1
14	BLVS018-B14	Flat Washer	M3	1
15	TS-2283102	Phillips Pan Hd Mach Screw	M3x0.5x10L	4
16	BLVS018-B16	Male Receptacle (Optional)		1
17	(see sect. 20.0)	Wired Pendant Control (Optional)		1
18	BLVS018-B18	Carabiner (Optional)		1
19	BLVS018-B19	Antenna		1

22.4.1 BLVS100 & 200 Motor & Housing – Exploded View

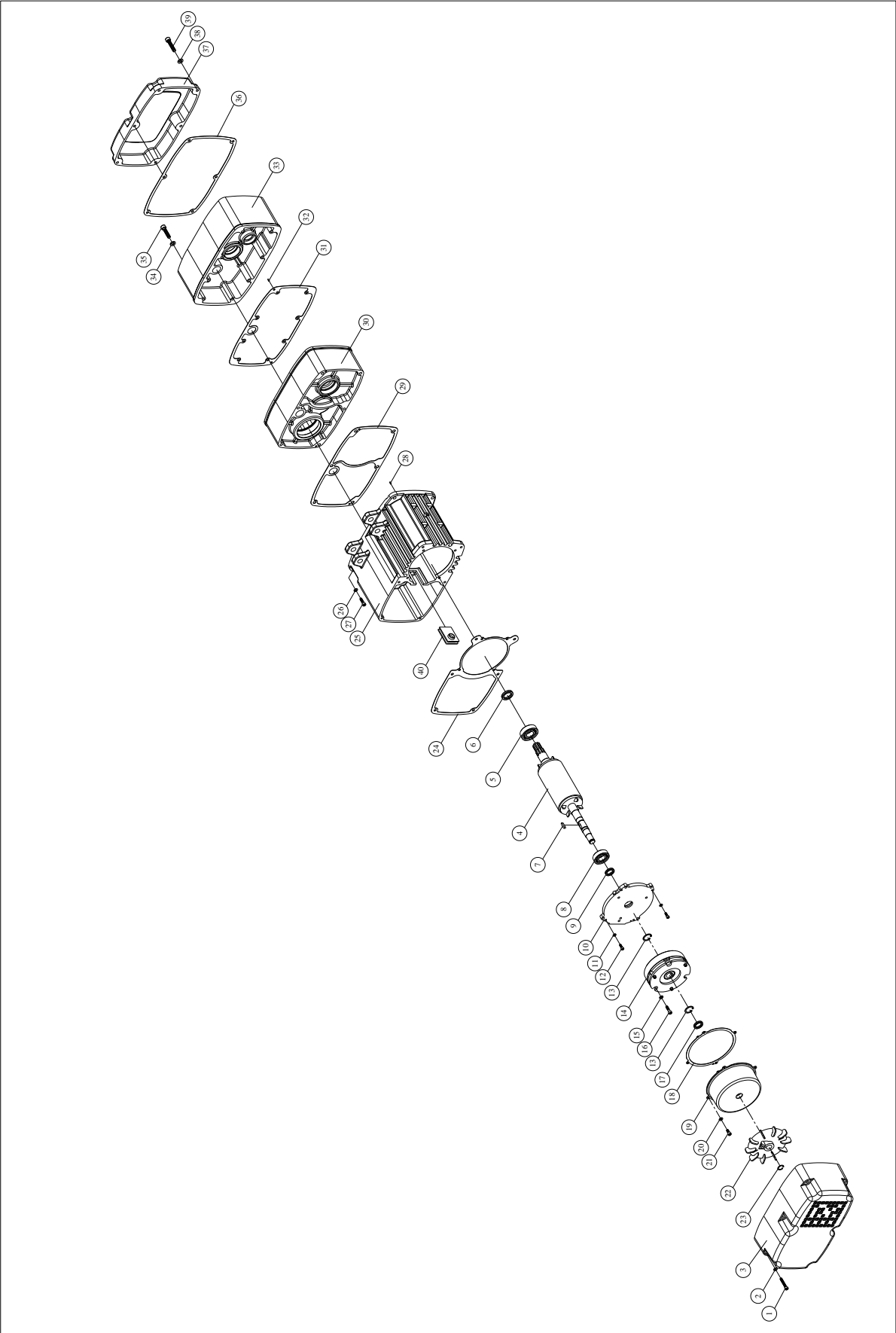

22.4.2 BLVS100 & 200 Motor & Housing – Parts List

Index No	Part No	Description	Size	Qty
1	TS-1502101	Socket Hd Cap Screw	M5x0.8x45	6
2	TS-2361051	Spring Washer	M5	6
3	BLVS100-A03	End Cover		1
4	BLVS100-A04	Motor Rotor		1
5	BB-62042RS	Bearing	6204 2RS	1
6	TS050-A07	Oil Seal	Ø20xØ35x8t	1
7	6293356	Key	6x6x20L	1
8	BB-62042RS	Bearing	6204 2RS	1
9	TS050-A07	Oil Seal	Ø20xØ35x8t	1
10	TS050-A11	Motor End Cover		1
11	TS-2361051	Spring Washer	M5	4
12	TS-1502051	Socket Hd Cap Screw	M5x0.8x20	4
13	1017067	Retaining Ring	S-19	2
14	TS050-A15	Brake Ass'y	SNT-102-075	1
15	TS-2361061	Spring Washer	M6	3
16	TS-1503081	Socket Hd Cap Screw	M6x1.0x35	3
17	TS050-A18	Oil Seal	VA18	1
18	TS050-A19	Brake End Cover Gasket		1
19	TS050-A20	Brake End Cover		1
20	TS-2361051	Spring Washer	M5	4
21	TS-1502021	Socket Hd Cap Screw	M5x0.8x10	4
22	TS050-A24	Fan	Ø124xØ14	1
23	F006042	Retaining Ring	S-14	1
24	TS050-A26	End Cover Gasket		1
25	BLVS100-A25	Motor Stator Ass'y		1
26	TS-2361081	Spring Washer	M8	6
27	TS-1504071	Hex. Bolt	M8x1.25x35	6
28	TS050-A30	Pin	Ø5x12	2
29	TS050-A31	Motor Gasket		1
30	BLVS100-A30	Gearbox		1
31	TS050-A33	Gearbox Gasket		1
32	TS050-A30	Pin	Ø5x12	2
33	BLVS100-A33	Gearbox Cover		1
34	TS-2361061	Spring Washer	M6	6
35	TS-1503121	Socket Hd Cap Screw	M6x1.0x55	6
36	TS050-A38	Electric Cover Gasket		1
37	BLVS100-A37	Electric Cover		1
38	TS-2361061	Spring Washer	M6	8
39	TS-1503091	Socket Hd Cap Screw	M6x1.0x40	8
40	BLVS100-A40	Waterproof Rubber		1

22.5.1 BLVS100 & 200 Hook – Exploded View

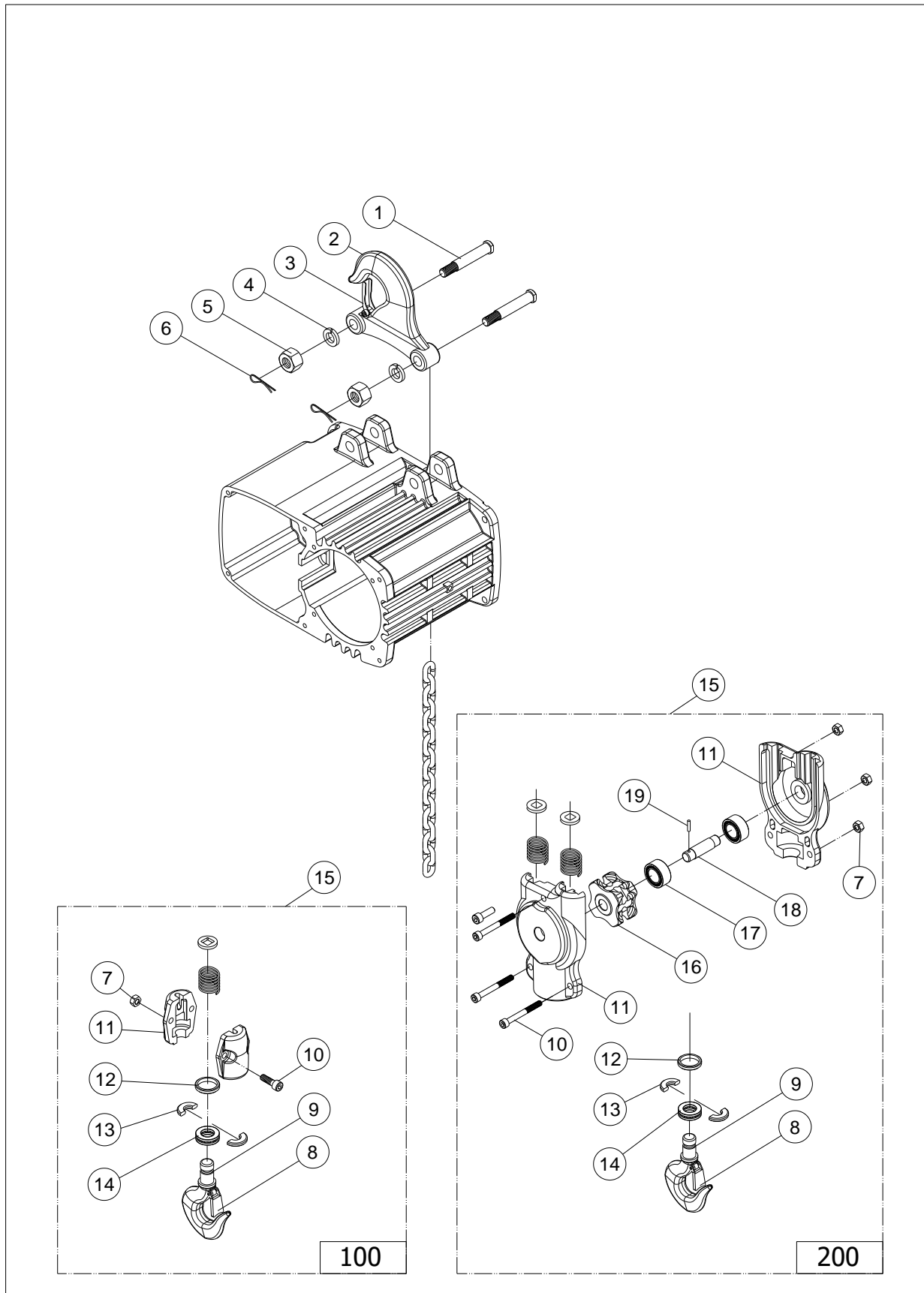

22.5.2 BLVS100 & 200 Hook – Parts List

Index No	Part No	Description	Size	Qty
1	TS050-B01	Lock Bolt	Ø14x83	2
2	TS100-B02	Top Hook Ass'y		1
3	BLVS050-A71	Safety Latch Ass'y		1
4	TS-2361121	Spring Washer	M12	2
5	TS-1540081	Nut	M12x1.75	2
6	BLVS018-A84	Cotter Pin	Ø3x30	2
7	TS-2342121	Nylon Nut	M8x1.25	2
	TS-2342121	Nylon Nut	M8x1.25	3
8	TS050-B08	Safety Latch Ass'y		1
	TS100-B08			1
9	TS100-B09	Bottom Hook Ass'y		1
	BLVS200-B09			1
10	TS-1504061	Socket Hd Cap Screw	M8x1.25x30	2
	TS-1504071	Socket Hd Cap Screw	M8x1.25x35	3
11	TS100-B11	Bottom Block Cover		1
	BLVS200-B11A	Bottom Block Cover A		1
	BLVS200-B11B	Bottom Block Cover B		1
12	TS050-B12	End Spacer		1
	BLVS200-B12			1
13	TS050-B13	Half Spacer		2
	BLVS200-B13			2
14	BB-2904	Thrust Bearing	2904	1
	BB-2905	Thrust Bearing	2905	1
15	TS100-B15	Bottom Hook Cover Ass'y		1
	BLVS200-B15			1
16	BLVS200-B16	Sprocket		1
17	BLVS200-B17	Needle Bearing	HK 25/26	1
18	BLVS200-B18	Sprocket Axle		1
19	BLVS200-B19	Spring Pin	Ø5x16	1

22.6.1 BLVS100 & 200 Load Chain – Exploded View

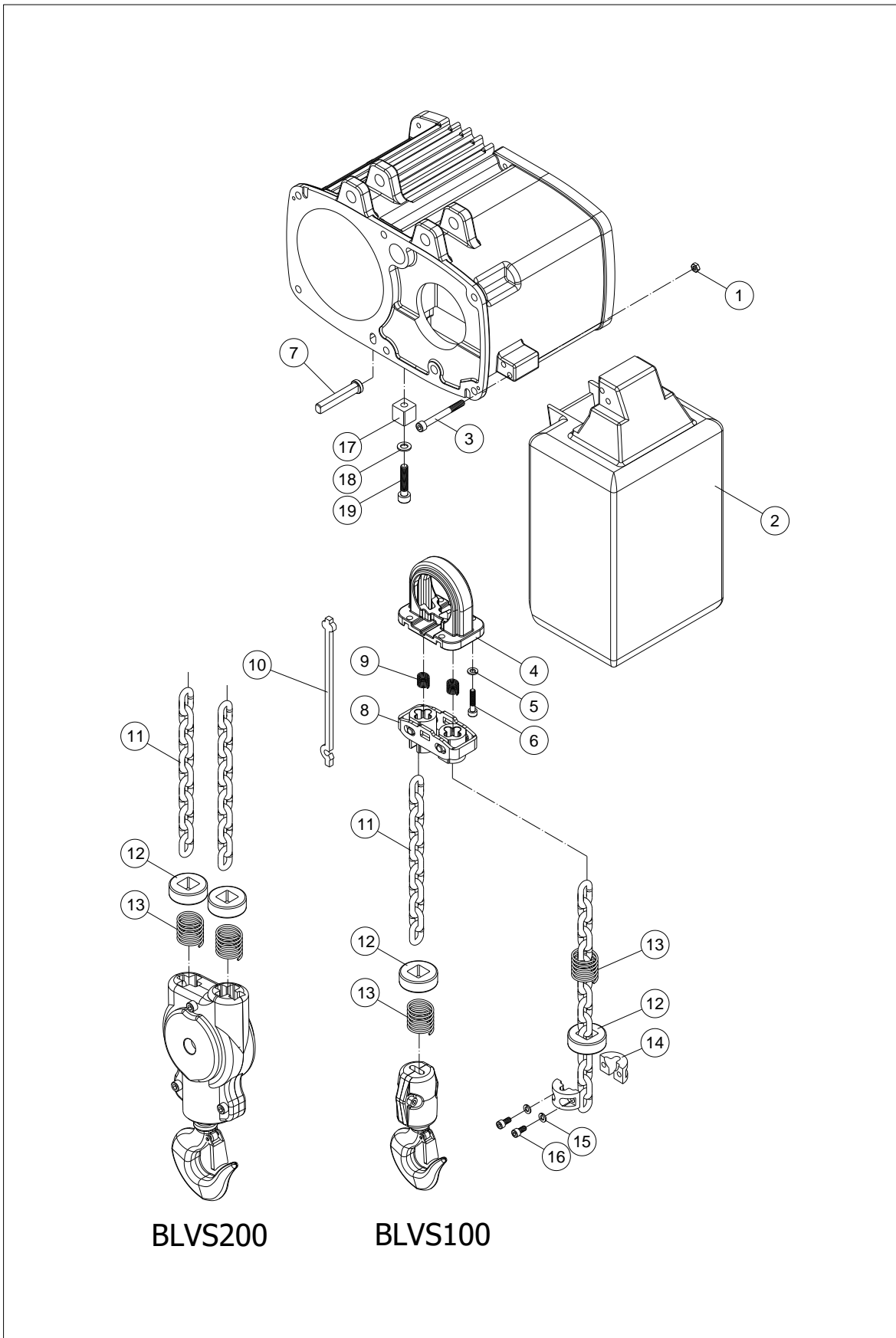

22.6.2 BLVS100 & 200 Load Chain – Parts List

Index No	Part No	Description	Size	Qty
1	TS-1541011	Nylon Nut	M5	2
2	(see sect. 19.0)	Chain Bucket		1
3	TS-2235501	Socket Hd Cap Screw	M5x0.8x50	2
	TS-2235801		M5x0.8x80	2
4	BLVS100-C06	Chain Regulator		1
5	TS-2361061	Spring Washer	M6	4
6	TS-1503041	Socket Hd Cap Screw	M6x1.0x16	4
7	BLVS100-C09	Chain Connecting Pin	Ø16x66	1
8	BLVS100-C10	Guide Tube Ass'y		1
9	TS100-C09	Spring		2
10	TS100-C10	Substitute Chain	Ø7.1x20.2	1
11	LCHAIN-7X20	Chain	Ø7.1x20.2	3.5M
	LCHAIN-7X20		Ø7.1x20.2	6.5M
12	TS050-C12	Limit Stopper Ass'y		2
	TS050-C12			3
13	TS050-C13	Spring		2
	TS050-C13			3
14	TS050-C14	Chain Stopper		2
15	TS-2361061	Spring Washer	M6	2
16	TS-1503051	Socket Hd Cap Screw	M6x1.0x20	2
17	TS050-C18	Fixed Block		1
18	TS-2361051	Spring Washer	M5	1
19	TS-1502051	Socket Hd Cap Screw	M5x0.8x20	1

22.7.1 BLVS100 & 200 Gear Box – Exploded View

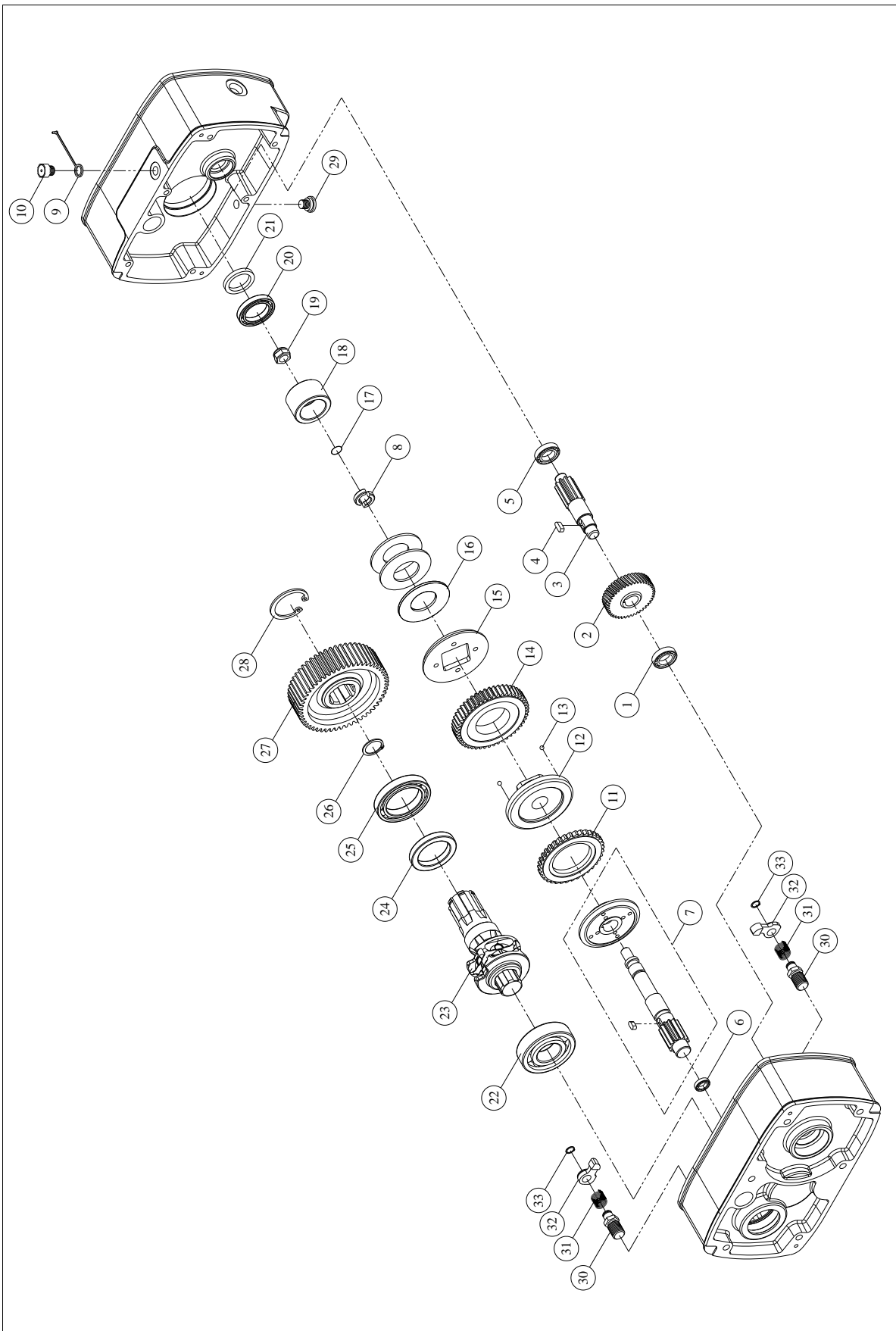

22.7.2 BLVS100 & 200 Gear Box – Parts List

Index No	Part No	Description	Size	Qty
1	BB-6002ZZ	Bearing	6002ZZ	1
2	TS050-D02	2nd Gear	M1.25x50Tx14L	1
3	TS050-D03	3rd Gear	M2x12Tx88L	1
4	BLVS018-A13	Key	6x6x12L	1
5	BB-6002ZZ	Bearing	6002 ZZ	1
6	BB-6204	Bearing	6204	1
7	BLVS100-D07	4th Gear Ass'y	M2x13T	1
8	BLVS050-A24	Load Brake Gear Spacer		2
9	BLVS018-A33	Air Plug		1
10	BLVS018-A32	Hex. Oil Plug		1
11	BLVS100-D11	Ratchet Ass'y		1
12	BLVS100-D12	Brake Bushing		1
13	SB-6MM	Ball	Ø6	3
14	BLVS100-D14	3rd Gear Ass'y	M2x49T	1
15	TS050-D15	Brake Body	Ø90x7.6L	1
16	TS050-D16	Disc Spring	Ø70xØ35.5x3t	3
17	TS050-D18	O-Ring	P-14	1
18	BLVS100-D18	Disc Spring Bushing		1
19	TS-2342161	Lock Nut	M16x1.5	1
20	BB-6910ZZ	Bearing	6910 ZZ	1
21	TS050-D25	Oil Seal	Ø50xØ68x9t	1
22	BB-6006ZZ	Bearing	6006ZZ	1
23	BLVS100-D23	Load Sheave		1
24	TS050-D28	Oil Seal	Ø35xØ50x8t	1
25	BB-6006ZZ	Bearing	6006ZZ	1
26	F006050	C-Retaining Ring, Ext	S-25	1
27	BLVS100-D27	5th Gear	M2x42T	1
28	F006097	C-Retaining Ring, Int	R-55	1
29	BLVS018-A40	Lubricant Drain Bolt		1
30	BLVS100-D30	Ratchet Pawl Pin		2
31	TS050-D35	Ratchet Pawl Spring		2
32	BLVS018-A36	Ratchet Pawl		2
33	F006098	C-Retaining Ring, Ext	S-11	2

22.8.1 BLVS100 & 200 Electric – Exploded View

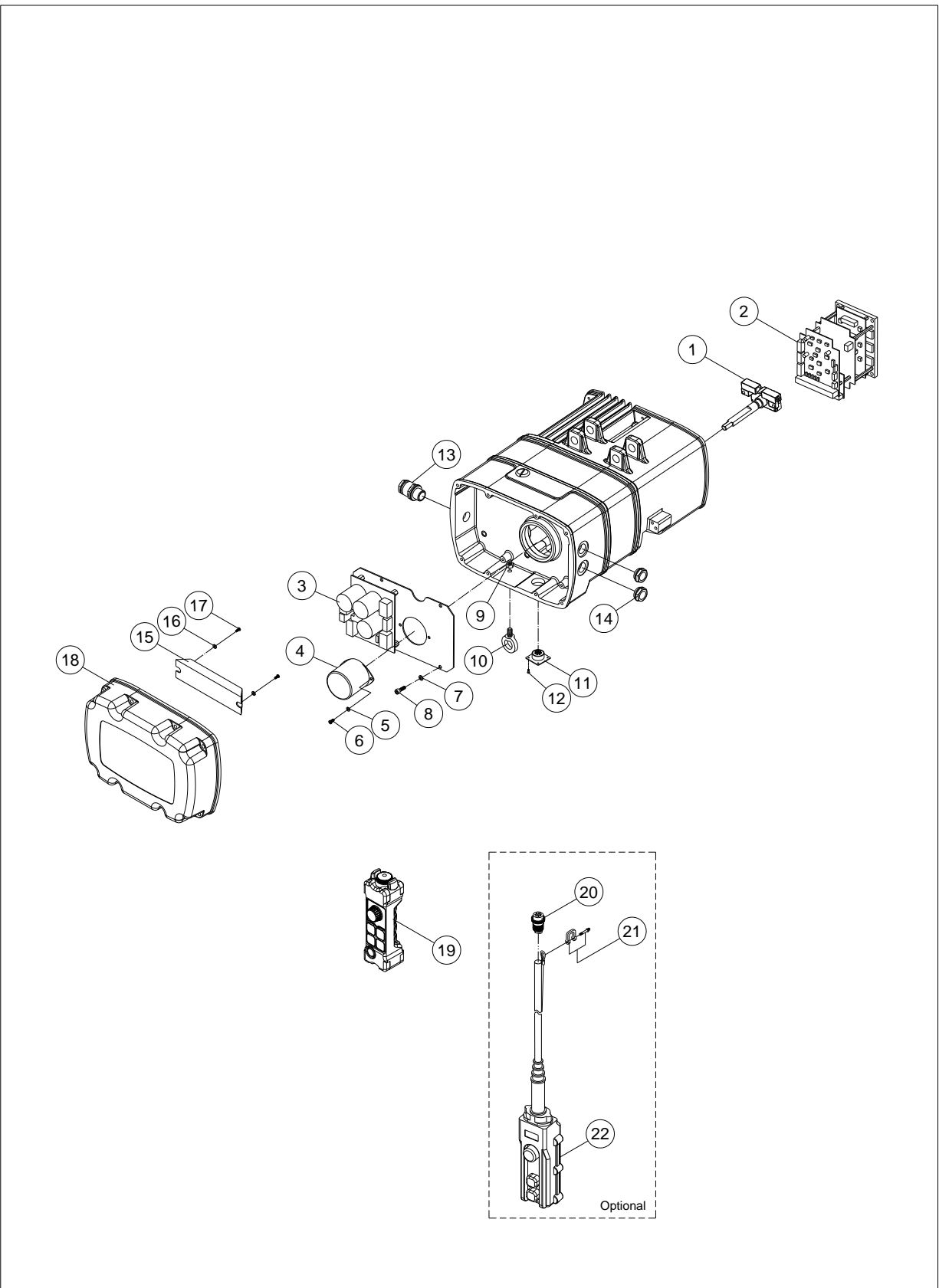

22.8.2 BLVS100 & 200 Electric – Parts List

Index No	Part No	Description	Size	Qty
1	BLVS100-E01	Upper & Lower Limit Switch.....		1
2	BLVS100-E02	DC Motor Controller Ass'y (RE:BLVS100-E03A)		1
3	BLVS100-E03	PFC Power Supply Ass'y (RE:BLVS100-E03A)		1
	BLVS100-E03A	PFC Power Supply Ass'y (includes #2 and #3)		1
4	TS050-E26	Cover		1
5	TS-2361041	Spring Washer	M4	2
6	TS-2284061	Cross Headed Screw	M4x0.7x6L	2
7	TS-2361051	Spring Washer	M5	4
8	TS-1502021	Socket Hd Cap Screw.....	M5x0.8x10L	4
9	TS-1541021	Nut	M6x1.0	1
10	BLVS018-B13	Eye Bolt	M6x1.0	1
11	BLVS018-B09	Female Receptacle.....		1
12	TS-2283102	Cross Headed Screw	M3x0.5x10L	4
13	TS050-E24	Cable Gland	M20-13	1
14	TS050-E25	Cable Gland	SPG-M20B M20x1.5	2
15	BLVS100-E15	Brake Resistance.....		1
16	TS-2361041	Spring Washer	M4	2
17	TS-1532032	Cross Headed Screw	M4x0.7x10	2
18	BLVS100-E18	Electric Cover		1
19	140192	Remote Controller.....		1
20	BLVS018-B20	Male Receptacle.....		1
21	BLVS100-E23	Shackle	3/16"	1
22	(see sect. 20.0)	Wired Pendant Control (Optional).....		

23.0 Electrical connections for BLVS series hoist

23.1 BLVS018, 025, 050 Wiring Diagram

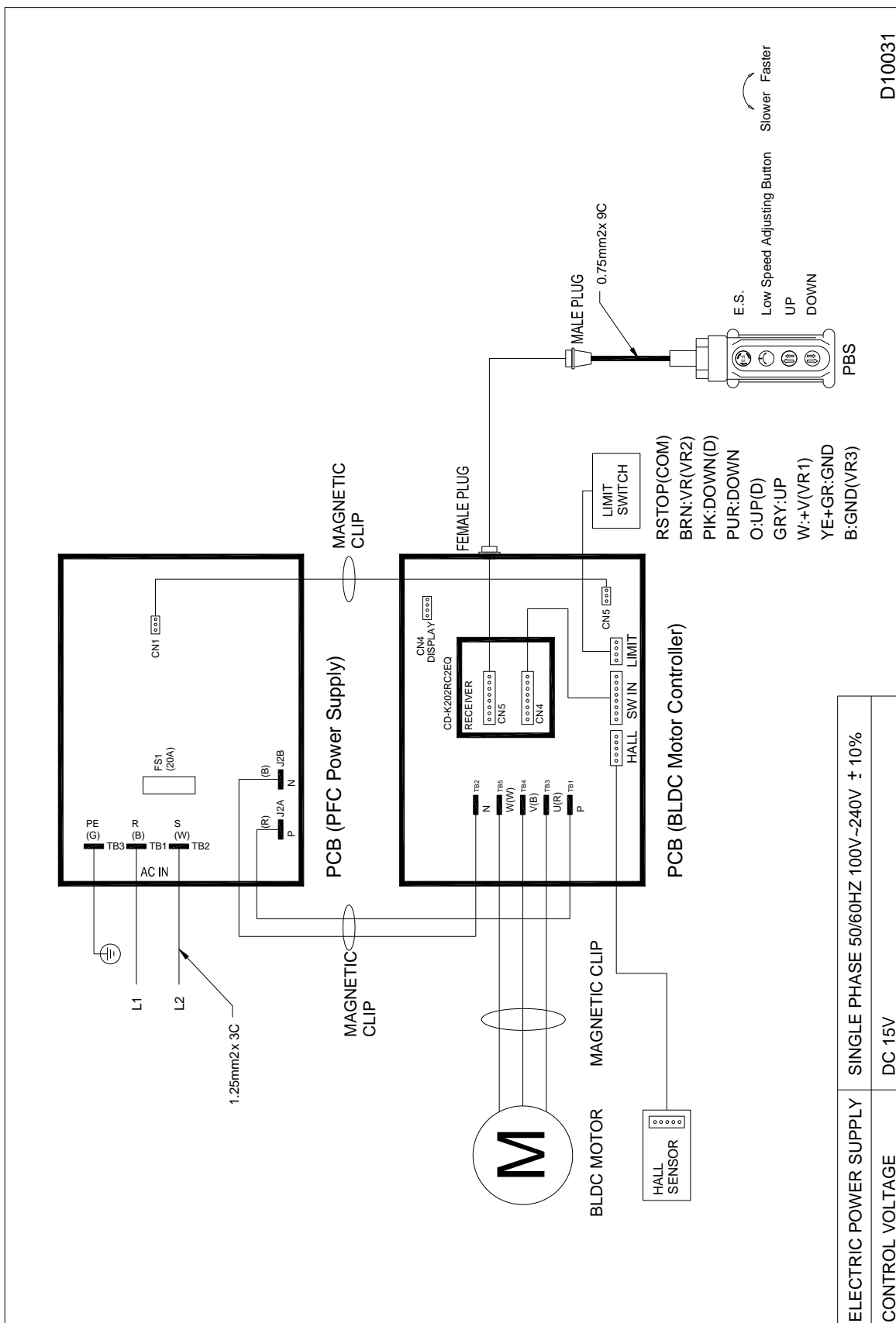

23.2 BLVS100, 200 Wiring Diagram

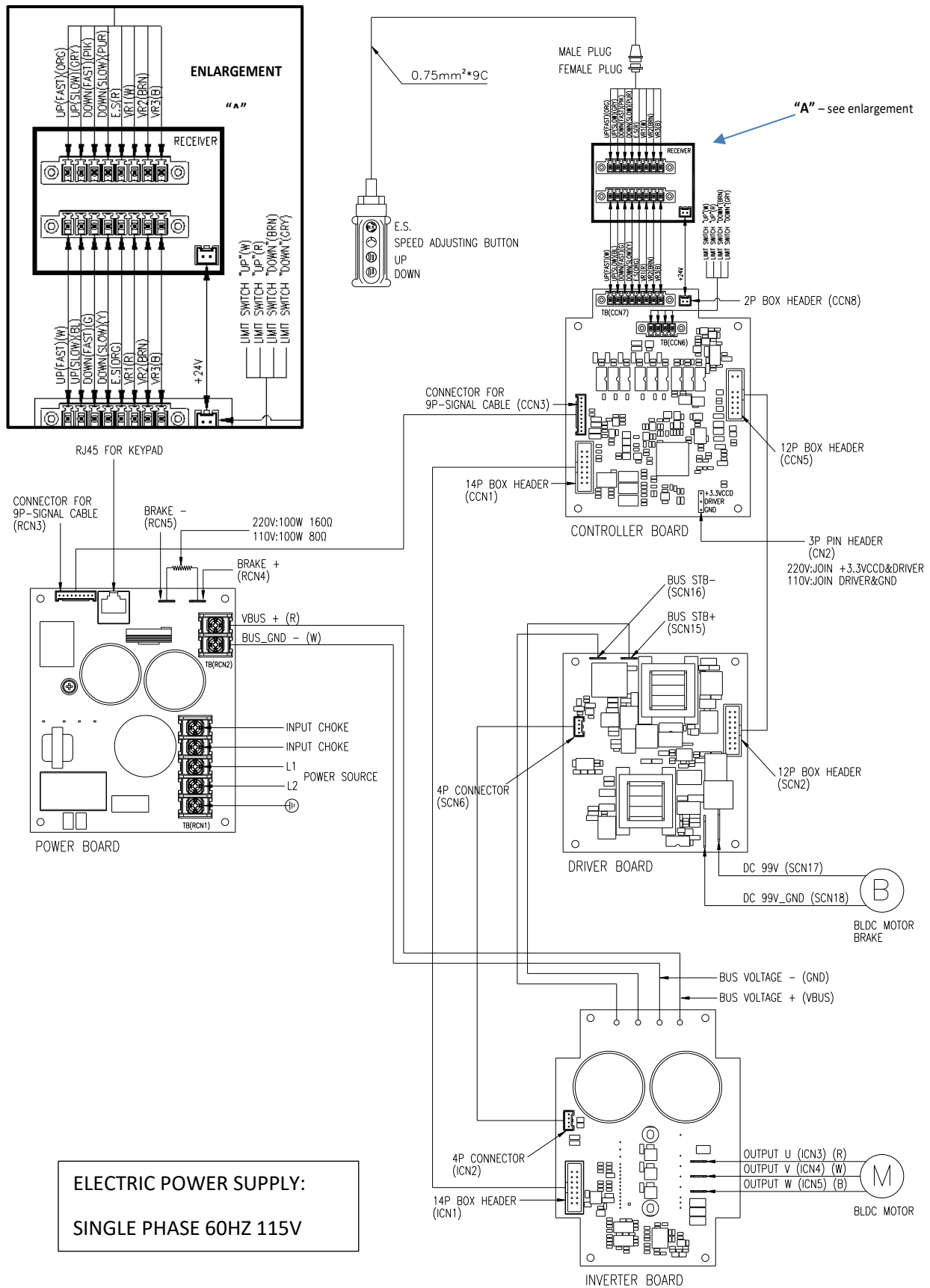

24.0 Warranty and Service

JET warrants every product it sells against manufacturers' defects. If one of our tools needs service or repair, please contact Technical Service by calling 1-800-274-6846, 8AM to 5PM CST, Monday through Friday.

Warranty Period

The general warranty lasts for the time period specified in the literature included with your product or on the official JET branded website.

- JET products carry a limited warranty which varies in duration based upon the product. (See chart below)
- Accessories carry a limited warranty of one year from the date of receipt.
- Consumable items are defined as expendable parts or accessories expected to become inoperable within a reasonable amount of use and are covered by a 90 day limited warranty against manufacturer's defects.

Who is Covered

This warranty covers only the initial purchaser of the product from the date of delivery.

What is Covered

This warranty covers any defects in workmanship or materials subject to the limitations stated below. This warranty does not cover failures due directly or indirectly to misuse, abuse, negligence or accidents, normal wear-and-tear, improper repair, alterations or lack of maintenance. JET woodworking machinery is designed to be used with Wood. Use of these machines in the processing of metal, plastics, or other materials outside recommended guidelines may void the warranty. The exceptions are acrylics and other natural items that are made specifically for wood turning.

Warranty Limitations

Woodworking products with a Five Year Warranty that are used for commercial or industrial purposes default to a Two Year Warranty. Please contact Technical Service at 1-800-274-6846 for further clarification.

How to Get Technical Support

Please contact Technical Service by calling 1-800-274-6846. **Please note that you will be asked to provide proof of initial purchase when calling.** If a product requires further inspection, the Technical Service representative will explain and assist with any additional action needed. JET has Authorized Service Centers located throughout the United States. For the name of an Authorized Service Center in your area call 1-800-274-6846 or use the Service Center Locator on the JET website.

More Information

JET is constantly adding new products. For complete, up-to-date product information, check with your local distributor or visit the JET website.

How State Law Applies

This warranty gives you specific legal rights, subject to applicable state law.

Limitations on This Warranty

JET LIMITS ALL IMPLIED WARRANTIES TO THE PERIOD OF THE LIMITED WARRANTY FOR EACH PRODUCT. EXCEPT AS STATED HEREIN, ANY IMPLIED WARRANTIES OF MERCHANTABILITY AND FITNESS FOR A PARTICULAR PURPOSE ARE EXCLUDED. SOME STATES DO NOT ALLOW LIMITATIONS ON HOW LONG AN IMPLIED WARRANTY LASTS, SO THE ABOVE LIMITATION MAY NOT APPLY TO YOU.

JET SHALL IN NO EVENT BE LIABLE FOR DEATH, INJURIES TO PERSONS OR PROPERTY, OR FOR INCIDENTAL, CONTINGENT, SPECIAL, OR CONSEQUENTIAL DAMAGES ARISING FROM THE USE OF OUR PRODUCTS. SOME STATES DO NOT ALLOW THE EXCLUSION OR LIMITATION OF INCIDENTAL OR CONSEQUENTIAL DAMAGES, SO THE ABOVE LIMITATION OR EXCLUSION MAY NOT APPLY TO YOU.

JET sells through distributors only. The specifications listed in JET printed materials and on official JET website are given as general information and are not binding. JET reserves the right to effect at any time, without prior notice, those alterations to parts, fittings, and accessory equipment which they may deem necessary for any reason whatsoever. JET® branded products are not sold in Canada by JPW Industries, Inc.

Product Listing with Warranty Period

90 Days – Parts; Consumable items
1 Year – Motors; Machine Accessories
2 Year – Metalworking Machinery; Electric Hoists, Electric Hoist Accessories; Woodworking Machinery used for industrial or commercial purposes; Air Tools
5 Year – Woodworking Machinery
Limited Lifetime – JET Parallel clamps; VOLT Series Electric Hoists; Manual Hoists; Manual Hoist Accessories; Shop Tools; Warehouse & Dock products; Hand Tools

NOTE: JET is a division of JPW Industries, Inc. References in this document to JET also apply to JPW Industries, Inc., or any of its successors in interest to the JET brand.



427 New Sanford Road
LaVergne, Tennessee 37086
Phone: 800-274-6848
www.jettools.com