



Operating Instructions and Parts Manual

Combination Belt/Disc Sander

Model JSG-6DC



with optional open stand



with optional closed stand

for models with serial no. 20050451 and higher

JET
427 New Sanford Road
LaVergne, Tennessee 37086
Ph.: 800-274-6848
www.jettools.com

Part No. M-708599
Revision H 05/2020
ECR 200515104020
Copyright © 2014 JET

Warranty and Service

JET warrants every product it sells against manufacturers' defects. If one of our tools needs service or repair, please contact Technical Service by calling 1-800-274-6846, 8AM to 5PM CST, Monday through Friday.

Warranty Period

The general warranty lasts for the time period specified in the literature included with your product or on the official JET branded website.

- JET products carry a limited warranty which varies in duration based upon the product. (See chart below)
- Accessories carry a limited warranty of one year from the date of receipt.
- Consumable items are defined as expendable parts or accessories expected to become inoperable within a reasonable amount of use and are covered by a 90 day limited warranty against manufacturer's defects.

Who is Covered

This warranty covers only the initial purchaser of the product from the date of delivery.

What is Covered

This warranty covers any defects in workmanship or materials subject to the limitations stated below. This warranty does not cover failures due directly or indirectly to misuse, abuse, negligence or accidents, normal wear-and-tear, improper repair, alterations or lack of maintenance. JET woodworking machinery is designed to be used with Wood. Use of these machines in the processing of metal, plastics, or other materials outside recommended guidelines may void the warranty. The exceptions are acrylics and other natural items that are made specifically for wood turning.

Warranty Limitations

Woodworking products with a Five Year Warranty that are used for commercial or industrial purposes default to a Two Year Warranty. Please contact Technical Service at 1-800-274-6846 for further clarification.

How to Get Technical Support

Please contact Technical Service by calling 1-800-274-6846. **Please note that you will be asked to provide proof of initial purchase when calling.** If a product requires further inspection, the Technical Service representative will explain and assist with any additional action needed. JET has Authorized Service Centers located throughout the United States. For the name of an Authorized Service Center in your area call 1-800-274-6846 or use the Service Center Locator on the JET website.

More Information

JET is constantly adding new products. For complete, up-to-date product information, check with your local distributor or visit the JET website.

How State Law Applies

This warranty gives you specific legal rights, subject to applicable state law.

Limitations on This Warranty

JET LIMITS ALL IMPLIED WARRANTIES TO THE PERIOD OF THE LIMITED WARRANTY FOR EACH PRODUCT. EXCEPT AS STATED HEREIN, ANY IMPLIED WARRANTIES OF MERCHANTABILITY AND FITNESS FOR A PARTICULAR PURPOSE ARE EXCLUDED. SOME STATES DO NOT ALLOW LIMITATIONS ON HOW LONG AN IMPLIED WARRANTY LASTS, SO THE ABOVE LIMITATION MAY NOT APPLY TO YOU.

JET SHALL IN NO EVENT BE LIABLE FOR DEATH, INJURIES TO PERSONS OR PROPERTY, OR FOR INCIDENTAL, CONTINGENT, SPECIAL, OR CONSEQUENTIAL DAMAGES ARISING FROM THE USE OF OUR PRODUCTS. SOME STATES DO NOT ALLOW THE EXCLUSION OR LIMITATION OF INCIDENTAL OR CONSEQUENTIAL DAMAGES, SO THE ABOVE LIMITATION OR EXCLUSION MAY NOT APPLY TO YOU.

JET sells through distributors only. The specifications listed in JET printed materials and on official JET website are given as general information and are not binding. JET reserves the right to effect at any time, without prior notice, those alterations to parts, fittings, and accessory equipment which they may deem necessary for any reason whatsoever. JET® branded products are not sold in Canada by JPW Industries, Inc.

Product Listing with Warranty Period

90 Days – Parts; Consumable items
1 Year – Motors; Machine Accessories
2 Year – Metalworking Machinery; Electric Hoists, Electric Hoist Accessories; Woodworking Machinery used for industrial or commercial purposes; Air Tools
5 Year – Woodworking Machinery
Limited Lifetime – JET Parallel clamps; VOLT Series Electric Hoists; Manual Hoists; Manual Hoist Accessories; Shop Tools; Warehouse & Dock products; Hand Tools

NOTE: JET is a division of JPW Industries, Inc. References in this document to JET also apply to JPW Industries, Inc., or any of its successors in interest to the JET brand.

Table of Contents

Warranty and Service.....	2
Table of Contents.....	3
Warning.....	4
Introduction	5
Specifications	6
On/Off Switch Padlock.....	7
Grounding Instructions.....	8
115 Volt Operation	8
230 Volt Operation	8
Extension Cords.....	9
Unpacking	10
Assembly.....	12
Disc Table	12
Belt Table	13
Installing Abrasives	13
Workstop Assembly.....	14
Dust Collection	14
Adjustments	15
Belt Table Adjustment	15
Belt Arm Orientation.....	16
Limit Screw Adjustment.....	16
Disc Table Adjustment	16
Miter Gauge.....	17
Belt Tracking Adjustment	18
Belt Replacement.....	18
Abrasive Disc Replacement	18
Maintenance.....	18
Troubleshooting	19
Optional Accessories	19
Replacement Parts.....	19
JSG-6DC Belt/Disc Sander Assembly.....	20
Parts List for JSG-6DC Belt/Disc Sander Assembly	21
Closed Stand Assembly (Optional)	24
Open Stand Assembly (Optional).....	25
Parts List for Open Stand Assembly (Optional).....	25
Electrical Connections.....	26



Warnings

1. Read and understand the entire owner's manual before attempting assembly or operation.
2. Read and understand the warnings posted on the machine and in this manual. Failure to comply with all of these warnings may cause serious injury.
3. Replace the warning labels if they become obscured or removed.
4. This sander is designed and intended for use by properly trained and experienced personnel only. If you are not familiar with the proper and safe operation of a belt/disc sander, do not use until proper training and knowledge have been obtained.
5. Don't use power tools in damp or wet locations, or expose them to rain.
6. This sander is intended to be used with wood and wood products only. Use of this sander and a dust collector with metal products is a potential fire hazard. If a dust collector is not used with this machine, remove the dust chutes.
7. Do not use this sander for other than its intended use. If used for other purposes, JET disclaims any real or implied warranty and holds itself harmless from any injury that may result from that use.
8. Always wear approved safety glasses/face shields while using this sander. (Note: Everyday eyeglasses only have impact resistant lenses; they are not safety glasses.) Also use face or dust masks if the cutting operation is dusty.
9. Before operating this sander, remove tie, rings, watches and other jewelry, and roll sleeves up past the elbows. Remove all loose clothing and confine long hair. Non-slip footwear or anti-skid floor strips are recommended. Do **not** wear gloves.
10. Do not operate this machine while tired or under the influence of drugs, alcohol or any medication.
11. Make certain the switch is in the **OFF** position before connecting the machine to the power supply.
12. Make certain the machine is properly grounded.
13. Make all machine adjustments or maintenance with the machine unplugged from the power source.
14. Remove adjusting keys and wrenches. Form a habit of checking to see that keys and adjusting wrenches are removed from the machine before turning it on.
15. Keep safety guards in place at all times when the machine is in use. If removed for maintenance purposes, use extreme caution and replace the guards immediately after maintenance is complete.
16. Make sure the sander is firmly secured to the stand or bench before use.
17. Check damaged parts. Before further use of the machine, a guard or other part that is damaged should be carefully checked to determine that it will operate properly and perform its intended function. Check for alignment of moving parts, binding of moving parts, breakage of parts, mounting and any other conditions that may affect its operation. A guard or other part that is damaged should be properly repaired or replaced.
18. Provide for adequate space surrounding work area and non-glare, overhead lighting.
19. Cluttered areas and benches invite accidents. Keep the area around the machine clean and free of scrap material, oil and grease.
20. Keep visitors a safe distance from the work area. **Keep children away.**
21. Make your workshop child proof with padlocks, master switches or by removing starter keys.
22. Give your work undivided attention. Looking around, carrying on a conversation and "horse-play" are careless acts that can result in serious injury.
23. Maintain a balanced stance at all times so that you do not fall or lean against the sanding belt/disc or other moving parts. Do not overreach or use excessive force to perform any machine operation.
24. Use the right tool at the correct speed and feed rate. Do not force a tool or attachment to do a job for which it was not designed. The right tool will do the job better and more safely.
25. Use recommended accessories; improper accessories may be hazardous.

26. Maintain tools with care. Keep tools sharp and clean for the best and safest performance. Follow instructions for lubricating the tool and changing accessories.
27. Support the workpiece adequately; maintain control of the work at all times.
28. Avoid kickback by sanding in accordance with directional arrows. When disc sanding, sand on the downward side of the disc; sanding on the upward side can cause the workpiece to fly up causing injury.
29. Sand with the grain of the wood.
30. Do not sand workpieces that are too small to be safely supported.
31. When sanding a large workpiece, use a support table to help stabilize it.
32. Turn off the machine and disconnect from power before cleaning. Use a brush or compressed air to remove chips or debris — do not use your hands.
33. Do not stand on the machine. Serious injury could occur if the machine tips over.
34. Never leave the machine running unattended. Turn the power off and do not leave the machine until it comes to a complete stop.
35. Remove loose items and unnecessary work pieces from the area before starting the machine.

 **WARNING:** This product can expose you to chemicals including lead which is known to the State of California to cause cancer and birth defects or other reproductive harm. For more information go to <http://www.p65warnings.ca.gov>.

 **WARNING:** Drilling, sawing, sanding or machining wood products generates wood dust and other substances known to the State of California to cause cancer. Avoid inhaling dust generated from wood products or use a dust mask or other safeguards for personal protection.

Wood products emit chemicals known to the State of California to cause birth defects or other reproductive harm. For more information go to <http://www.p65warnings.ca.gov/wood>.

Familiarize yourself with the following safety notices used in this manual:

 **CAUTION** This means that if precautions are not heeded, it may result in minor injury and/or possible machine damage.

 **WARNING** This means that if precautions are not heeded, it may result in serious or even fatal injury.

- - SAVE THESE INSTRUCTIONS - -

Introduction

This manual is provided by JET covering the safe operation and maintenance procedures for a JET Model JSG-6DC Belt/Disc Sander. This manual contains instructions on installation, safety precautions, general operating procedures, maintenance instructions and parts breakdown. This machine has been designed and constructed to provide consistent, long-term operation if used in accordance with instructions set forth in this manual. If there are any questions or comments, please contact either your local supplier or JET. JET can also be reached at our web site: www.jettools.com.

Specifications

Model Number.....	JSG-6DC
Stock Numbers:	
Sander only	708599
Sander with optional closed stand	708598K
Sander with optional open stand	708599K
Belt Section:	
Sanding Belt (L x W)(in.)	48 x 6
Belt Table Tilt (deg.)	-20 to 45
Belt Table (L x W)(in.)	14-3/4 x 7-1/2
Miter Groove (in.)	3/4 x 3/8
Belt Speed (SFPM)	2500
Belt Table Positive Stops (deg.)	45 and 90
Disc Section:	
Disc Diameter (in.)	12
Arbor Size (in.)	3/4
Disc Table Tilt (deg.)	-25 to 45
Disc Table (L x W)(in.)	16-1/2 x 9
Miter Groove (in.)	3/4 x 3/8
Disc Speed (RPM)	1725
Disc Table Positive Stops (deg.)	45 and 90
Dust Port Diameter (in.)	4
Dust Collection Recommended Minimum Capacity (CFM).....	450
Motor	TEFC Induction (Capacitor Start), 1-1/2HP, 1PH, 115/230V (pre-wired 115V), 12.8/6.2A, 60Hz
Overall Dimensions:	
with Belt Arm Horizontal (L x W x H/in.)	35 x 22 x 18
with Belt Arm Vertical (L x W x H/in.)	35 x 22 x 34-1/2
Footprint (in.)	18-1/2 x 15
Approximate Weight (Net/Shipping)(lbs.)	215/229
Accessory Stands:	
Approximate Weight of Open Stand (Net/Shipping)(lbs.)	25/28
Approximate Weight of Closed Stand (Net/Shipping)(lbs.)	55/61

The above specifications were current at the time this manual was published, but because of our policy of continuous improvement, JET reserves the right to change specifications at any time and without prior notice, without incurring obligations.

On/Off Switch Padlock

The Sander is equipped with a push-button switch that will accept a safety padlock (not included). To safeguard your machine from unauthorized operation and accidental starting by young children, the use of a padlock is highly recommended.

To lock out the switch:

1. Open the padlock. See Figure 1.
2. Insert through holes in the start button.
3. Close the padlock.
4. Secure the key in a safe place.

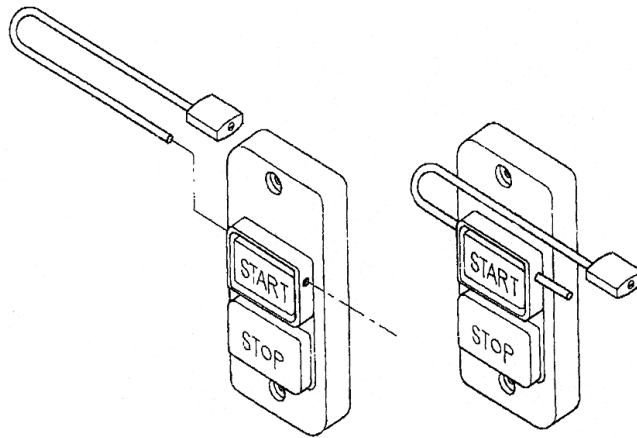

Figure 1

Grounding Instructions

⚠WARNING Electrical connections must be made by a qualified electrician in compliance with all relevant codes. This machine must be properly grounded to help prevent electrical shock and possible fatal injury.

In the event of a malfunction or breakdown, grounding provides a path of least resistance for electric current to reduce the risk of electric shock. This tool is equipped with an electric cord having an equipment-grounding conductor and a grounding plug. The plug must be plugged into a matching outlet that is properly installed and grounded in accordance with all local codes and ordinances.

Do not modify the plug provided. If it will not fit the outlet, have the proper outlet installed by a qualified electrician.

Improper connection of the equipment-grounding conductor can result in a risk of electric shock. The conductor, with insulation having an outer surface that is green with or without yellow stripes, is the equipment-grounding conductor. If repair or replacement of the electric cord or plug is necessary, do not connect the equipment-grounding conductor to a live terminal.

Check with a qualified electrician or service personnel if the grounding instructions are not completely understood, or if in doubt as to whether the tool is properly grounded. Use only three wire extension cords that have three-prong grounding plugs and three-pole receptacles that accept the tool's plug.

Repair or replace a damaged or worn cord immediately.

115 Volt Operation

As received from the factory, your sander is wired to run at 115 volt operation. This sander when wired for 115 volts, is intended for use on a circuit that has an outlet and a plug that looks the one illustrated in Figure 2. A temporary adapter, which looks like the adapter illustrated in Figure 3, may be used to connect this plug to a two-pole receptacle, as shown in Figure 3 if a properly grounded outlet is not available. The temporary adapter should only be used until a properly grounded outlet can be installed by a qualified electrician. **This adapter is not applicable in Canada.** The green colored rigid ear, lug, or tab, extending from the adapter, must be connected to a permanent ground such as a properly grounded outlet box, as shown in Figure 3.

It is recommended that the JSG-6DC Belt/Disc Sander, when operated at **115 volt**, be connected to a grounded and dedicated, minimum 30 amp circuit with a 30 amp circuit breaker or time delay fuse. **Local codes take precedence over recommendations.**

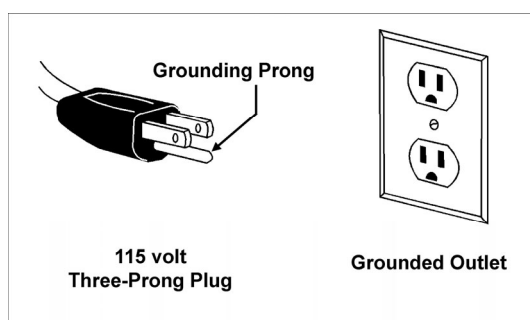

Figure 2

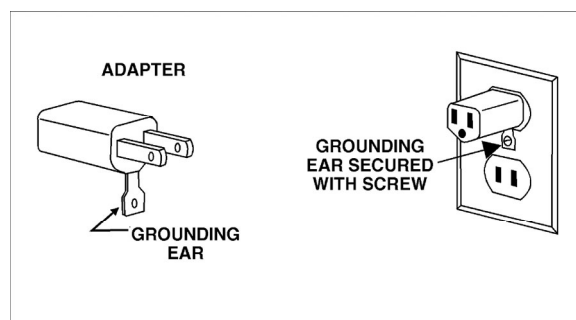

Figure 3

230 Volt Operation

If 230V, single-phase operation is desired, the following instructions must be followed:

1. Disconnect the machine from the power source.
2. This sander is supplied with four motor leads that are connected for 115V operation, as shown in Figure 4. Remove the switch box, and reconnect these four motor leads for 230V operation, as shown in Figure 5. Re-install the switch box.

- The 115V attachment plug (shown in Figure 6) supplied with the sander, must be replaced with a UL/CSA listed plug suitable for 230V operation (shown in Figure 7). Contact your local authorized JET service center or qualified electrician for proper procedures to install the plug. The sander must comply with all local and national codes after the 230 volt plug is installed.
- The band saw with a 230 volt plug should only be connected to an outlet having the same configuration (see Figure 7). No adapter is available or should be used with the 230 volt plug.

Important: In all cases (115 or 230 volts), make certain the receptacle in question is properly grounded. If you are not sure, have a registered electrician check the receptacle.

It is recommended that the JSG-6DC Belt/Disc Sander, when operated at **230 volt**, be connected to a grounded and dedicated, minimum 15 amp circuit with a 15 amp circuit breaker or time delay fuse. **Local codes take precedence over recommendations.**

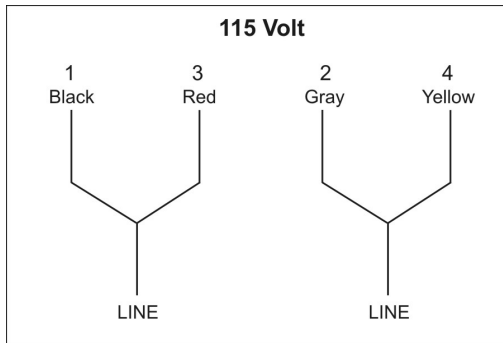

Figure 4

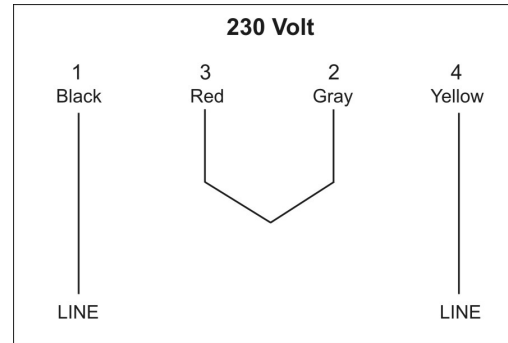

Figure 5

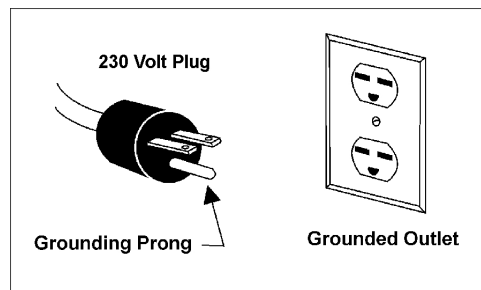

Figure 6

Extension Cords

If an extension cord is necessary, make sure the cord rating is suitable for the amperage listed on the machine's motor plate. An undersized cord will cause a drop in line voltage resulting in loss of power and overheating.

Use the chart in Figure 7 as a general guide in choosing the correct size extension cord for the Sander. If in doubt, use the next heavier gauge. The smaller the gauge number, the heavier the cord.

Recommended Minimum Gauge (AWG) of Extension Cords

Ampere Rating	Volts	Total Length of Cord in Feet			
	115 V	25 ft.	50 ft.	100 ft.	150 ft.
230 V	50 ft.	100 ft.	200 ft.	300 ft.	
AWG					
< 6		18	16	16	14
6 to 10		18	16	14	12
10 to 12		16	16	14	12
12 to 16		14	12	Not recommended	Not recommended

Figure 7

Unpacking

Open shipping carton(s) and check for shipping damage. Report any damage immediately to your distributor and shipping agent. Do not discard any shipping material until the Sander is assembled and running properly.

Compare the contents of your carton(s) with the following parts list to make sure all parts are intact. Missing parts, if any, should be reported to your distributor. Read the instruction manual thoroughly for assembly, maintenance and safety instructions.

Contents of Main Carton

See Figure 8.

- 1 Belt/Disc Sander (A)
- 1 Belt Sanding Table (B)
- 1 Disc Sanding Table (C)
- 1 Miter Gauge Assembly (D)
- 1 Workstop Assembly (E)
- 2 Lock Knobs (F)
- 1 Belt Tensioning Handle w/ Nut (G)
- 1 Table Lock Handle (H)
- 1 12-inch Abrasive Disc (I)
- 1 6 x 48-inch Abrasive Belt (J)
- 1 Operator's Manual (not shown)
- 1 Warranty Card (not shown)
- 1 Hardware Bag (K), containing:
 - 1 Hex Key, 6mm
 - 4 Socket Hd Cap Screws, M10 x 80
 - 1 Flat Washer, M10
 - 8 Flat Washers, M10 x \varnothing 20
 - 4 Lock Washers, M10
 - 4 Hex Nuts, M10

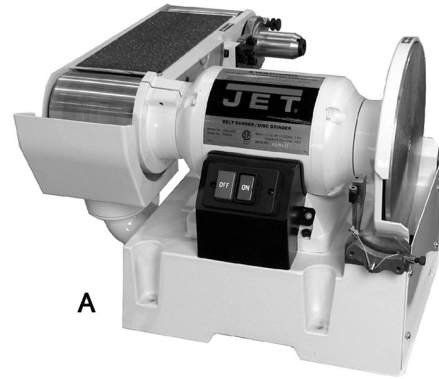

A



K

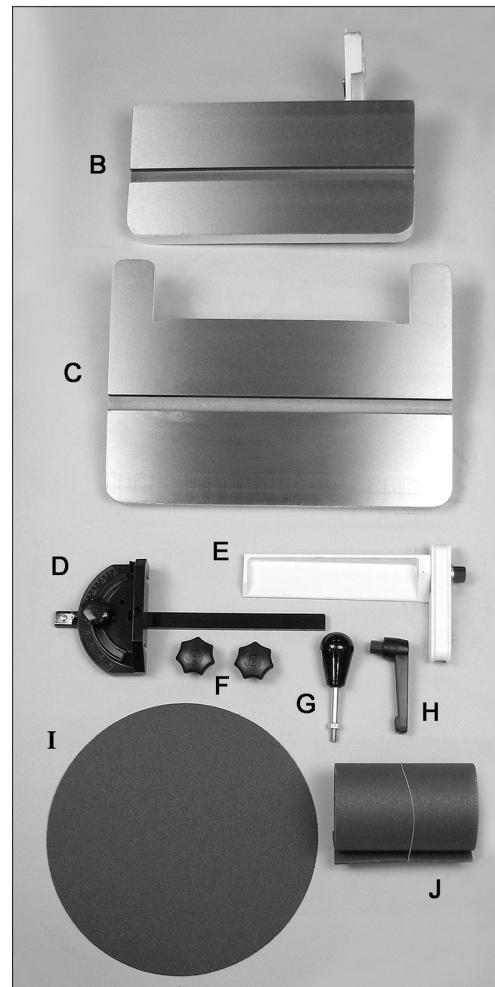

B

C

D

E

F

G

H

I

J

Figure 8

Contents of Closed Stand Carton:
(Optional Accessory – p/n 708598)

See Figure 9.

- 1 Stand
- 1 Owner's Manual (not shown)
- 1 Hardware Bag*, containing:
 - 4 Hex Cap Screws, M10 x 80
 - 8 Flat Washers, M10
 - 4 Lock Washers, M10
 - 4 Hex Nuts, M10

(*Note: The closed stand hardware bag contains the same fasteners as the sander hardware bag, and will not be needed if you purchased sander and stand together.)



Figure 9
(Optional Accessory)

Contents of Open Stand Carton:
(Optional Accessory – p/n 708566)

See Figure 10.

- 1 Top
- 4 Legs
- 4 Long Cross Braces
- 4 Short Cross Braces
- 1 Owner's Manual (not shown)
- 1 Hardware Bag, containing:
 - 40 Carriage Bolts, M8x16
 - 40 Lock Washers, M8
 - 40 Flat Washers, M8
 - 40 Hex Nuts, M8

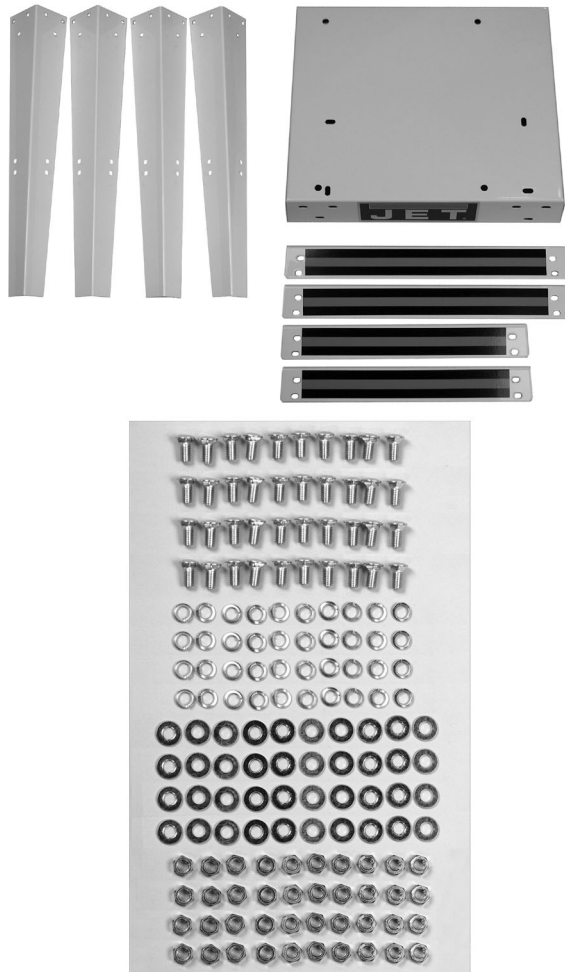

Figure 10
(Optional Accessory)

Assembly

Tools required for assembly:

- 4mm Hex Key
- 6mm Hex Key (provided)
- 13mm open-end wrench
- (2) 11/16" wrenches or sockets

⚠WARNING Machine is heavy! Use caution when lifting out of the shipping carton and moving to a final location. Stand or bench must be stable enough to support heavy weight.

1. Use a hoist with straps to remove the Sander from the carton. Prevent straps from contacting any levers or switches while lifting.
2. Carefully position the machine on a workbench or one of the optional JET stands. (Consult the assembly instructions that accompanied the stand.)
3. Bolt the unit firmly to secure it in position. Figure 11 shows it being bolted to the optional closed stand. Use the four M10x80 hex cap screws, with M10 lock washers, flat washers and hex nuts. Tighten hex nut while holding the screw head stationary, using two 11/16" wrenches. Remove lifting straps.
4. Exposed metal surfaces have been factory-coated with a protectant. Remove this using a soft cloth and a solvent or cleaner/ degreaser. (Note: Keep solvents away from painted surfaces and plastic parts, and do not use an abrasive pad, as it may scratch the polished metal surfaces.)

⚠WARNING Machine should be disconnected from power during all assembly procedures.

Disc Table

1. Remove the left and right trunnion brackets (A, Figure 12) from the trunnion holder (B).
2. Make sure the stop block (shown in Figure 23) is flipped out of the way.
3. Place the disc table on top of the trunnion assemblies and position each trunnion bracket (A) so that it slips onto the threaded stud and two pins of the trunnion holder (B), while engaging the lip of the table trunnion (C).

Note: The trunnion brackets are not identical; make sure the bracket with the raised indicator line is installed on the left side of the table.

4. Install a lock knob (D) on each threaded stud and tighten to hold the table in position.

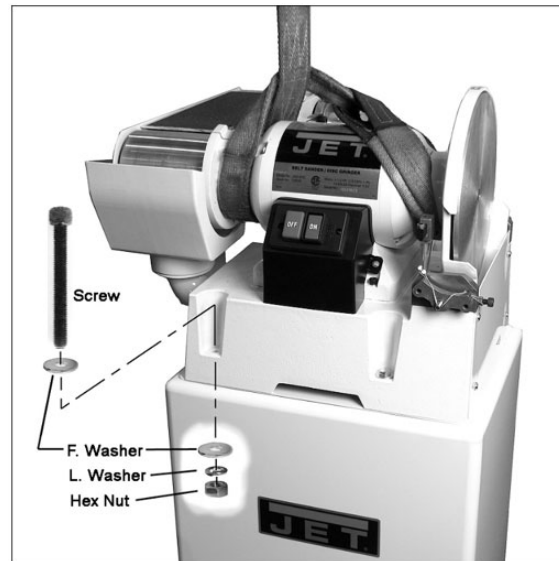

Figure 11
(closed stand optional)

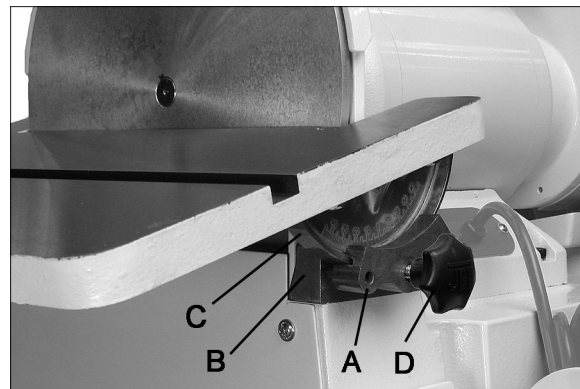

Figure 12



5. See “Adjustments” section for further instruction on adjusting the disc table.

Belt Table

1. Loosen the sanding platen lock screw (E, Figure 13) with a 6mm hex wrench, and tilt the belt arm to a vertical position. Re-tighten the lock screw.
2. Guide the belt table trunnion onto the stud, as shown in Figure 14. The raised track on the trunnion must fit into the groove on the belt arm.
3. Place the remaining M10 flat washer onto the stud (Figure 15).
4. Thread the nut of the table lock handle (Figure 15) onto the stud. To do this quickly, pull out on the handle, while tightening the nut with a 4mm hex wrench. When the nut is fully tightened onto the stud, release the handle, making sure it seats itself back onto the nut.

Note: The table lock handle can be repositioned at any time for convenience by pulling out on the handle, rotating it to new position, then releasing it. Make sure it re-seats itself on the nut.

5. Screw the belt tensioning handle (Figure 16) into the threaded hole in the belt tracking assembly, and tighten the hex nut against the shaft with a 13mm wrench.
6. See “Adjustments” section for further instruction on adjusting the belt table.

Installing Abrasives

Abrasive Disc

Note: You may wish to check the angle setting of the table before installing the abrasive disc. See “Disc Table Adjustment”.

To install the abrasive disc:

1. Disconnect machine from power source.
2. Make sure the aluminum disc is clean and dry.
3. Peel the backing from the abrasive and carefully insert it between disc and table; align and press into place.
4. Rotate disc a half turn and press other half of abrasive into place. Make sure to remove any entrapped air by pressing all parts of the abrasive against the disc.

Figure 13

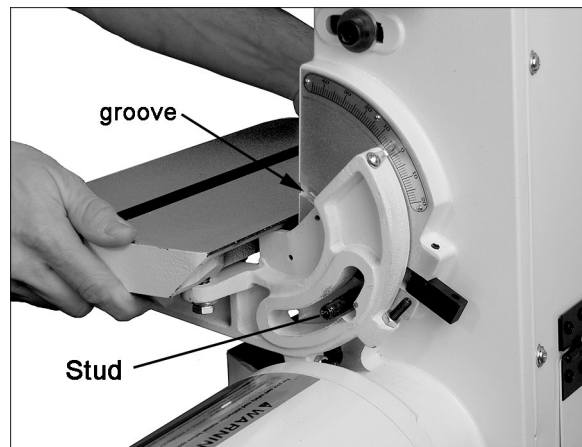

Figure 14



Figure 15

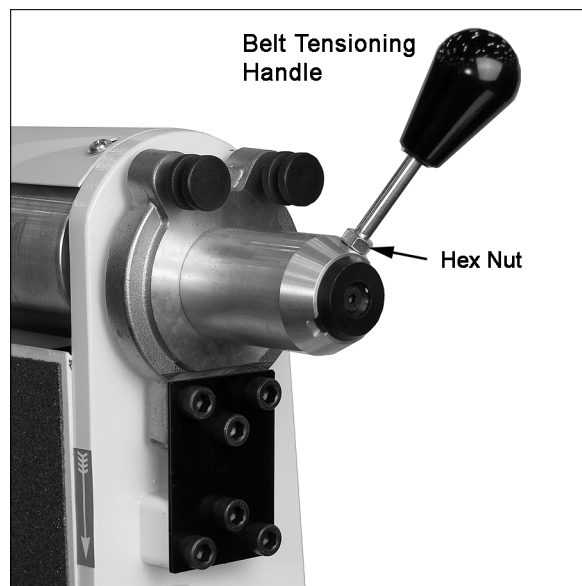

Figure 16

Abrasive Belt

1. Disconnect machine from power source.
2. Raise the belt arm to vertical position.
3. Loosen lock screw and open left side panel.
4. Most brands of replacement abrasives are directional, and must be installed in the proper direction. Directional belts are so indicated on the backing material by arrows. The direction of the abrasive should match that of the arrow on the platen assembly (Figure 17).

NOTE: Failure to comply with abrasive belt directional instructions may result in premature belt breakage.

5. Once the belt direction has been determined, pull the belt tensioning handle toward you with one hand, while using the other hand to slide the belt onto both drums and over the platen pad. See Figure 17.
6. Center the belt on the platen and release the belt tensioning handle.
7. Before operating, the belt should be tracked. See “Belt Tracking Adjustment.”



Figure 17

Workstop Assembly

When the sanding belt is to be used in the horizontal position, the table may be used as a fence; or the table may be removed and the workstop assembly installed.

Refer to Figure 18.

1. Remove table and trunnion assembly by removing the table lock handle and washer.
2. Slide workstop bracket onto stud and fasten with the washer and lock handle.
3. Adjust workstop to clear belt before starting machine.

Dust Collection

It is strongly recommended that a dust collection system (not included) be connected to the sander. Mount a 4-inch hose to the sander's dust port and secure with a hose clamp. (Note: Dryer vent hose is not suitable for such use).

The dust collector should have sufficient capacity for this size machine; a minimum rating of 450 CFM (cubic feet per minute) is recommended.

A variety of JET dust collectors is available; see our website at www.jettools.com.

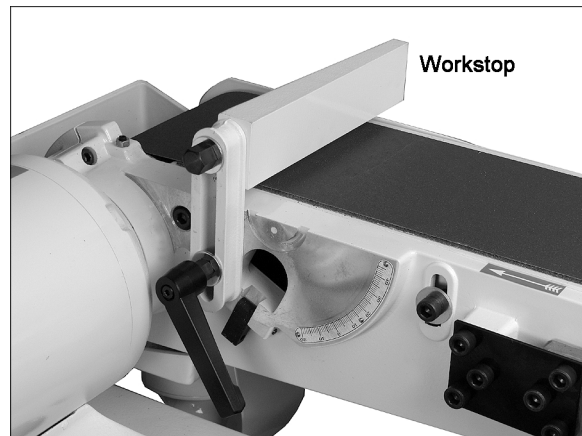

Figure 18

Adjustments

Tools required for adjustments:

- 3mm hex key
- 6mm hex key (provided)
- 10mm wrench
- 13mm wrench
- Combination and/or machinist's square
- Cross-point Screwdriver

Belt Table Adjustment

1. Disconnect machine from the power source.
2. Place a square on the table and up against the platen or abrasive belt, as shown in Figure 19.
3. Loosen the table lock handle and move the table until the square sits flush to both surfaces at 90°. Tighten the lock handle.
4. Place a combination square in the miter gauge slot and check the distance from the slot to the face of the platen. See Figure 20. Slide the square along the slot to the other side of the platen and check the distance. The distances should be equal to ensure that the miter gauge travels parallel to the belt.
5. If the table is not parallel, loosen the screws below the table (A, Figure 21) with a 13mm wrench, and nudge the table until parallel. Re-tighten screws.

Note: Always maintain a gap of approximately 1/16" between the table edge and the abrasive belt.

Once the table is square and parallel to the belt, verify the stops, as follows:

Adjust 90° Stop

6. With the table locked at 90°, loosen the hex nut on the 90° stop, and adjust the set screw to seat against the stop block. See Figure 19. Re-tighten hex nut to secure the setting.
7. If angle indicator adjustment is necessary, loosen the screw and shift the pointer to zero, and re-tighten the screw.

Adjust 45° Stop

8. Flip the stop block out of the way, and tilt the table down to 45°. Verify the setting of the 45° angle stop (Figure 19). Use the same procedure as above but with a 45° measuring device on the table. Correct the stop as needed.

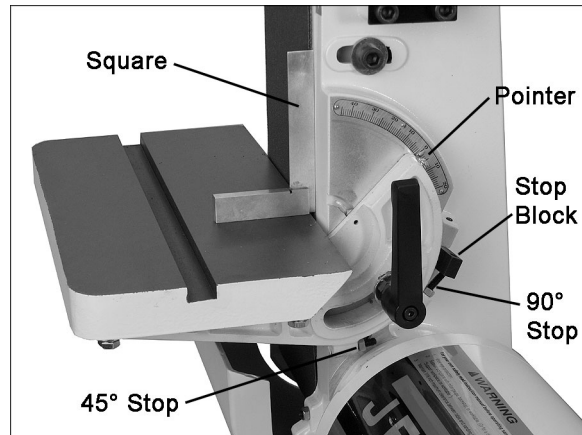

Figure 19

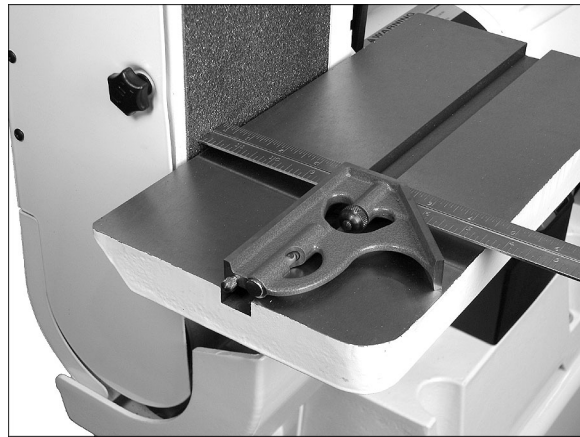

Figure 20

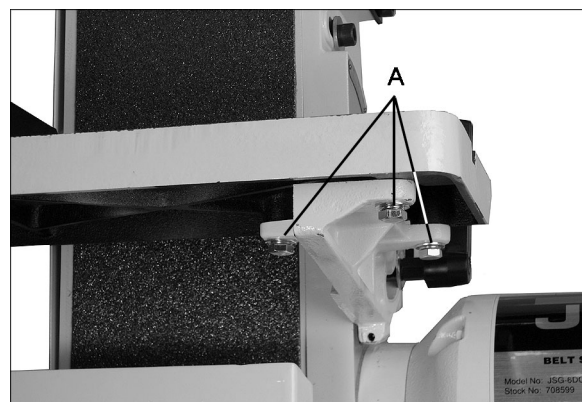

Figure 21

Belt Arm Orientation

Loosen the belt arm lock screw (see Figure 13) to tilt the belt arm to vertical or horizontal position. The belt arm can also be secured at any angle between. Always tighten the screw before operating.

Note: Belt tracking may require re-adjustment if the belt assembly is moved from vertical to horizontal or back again.

Limit Screw Adjustment

This set screw (Figure 22) limits the rotation of the belt arm to vertical and horizontal positions, and has been pre-set. If it should ever need re-adjustment:

1. Loosen lock nut on the set screw with a 10mm wrench.
2. With a 3mm hex key, turn set screw all the way in until it bottoms out. Back screw out three turns and re-tighten lock nut, while holding screw in place.

Disc Table Adjustment

1. Disconnect machine from power source.
2. Place a square on the table and against the disc. See Figure 23. Loosen both lock knobs, move the table until the square sits flush to both surfaces at 90°, and re-tighten both knobs. Note: You may need to pivot the stop block out of the way.
3. Place a combination square in the miter gauge slot and check the distance from the slot to face of the disc. See Figure 24. Slide the square along the slot to the other side of the disc and check the distance. The distances should be equal to ensure that the miter gauge travels parallel to the disc.
4. If table is not parallel, loosen the four screws holding the table to the trunnions (B, Figure 25) with a 12mm wrench, and nudge the table until parallel. Re-tighten screws.

Note: Always maintain a gap of approximately 1/16" between the table edge and the abrasive disc.

Once the table is square and parallel to the disc, verify the stops, as follows:

Adjust 90° Stop

5. Loosen lock nut on the 90° stop (Figure 23) with a 10mm wrench. Turn the set screw down (3mm hex key) to contact the table. Re-tighten lock nut.



Figure 22

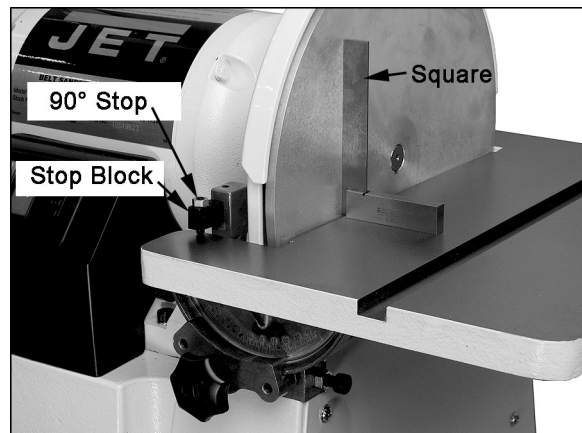

Figure 23



Figure 24

Adjust 45° Stop

6. To adjust the 45° stop, pivot the 90° stop block out of the way, and tilt the table down against the 45° stop screw (Figure 25). Check the angle with a 45° measuring device on the table and against the disc.
7. If adjustment is necessary, loosen the hex nut, turn the stop screw as needed, and re-tighten the hex nut to secure the setting.

Adjust Rear Stop

The rear stop (Figure 26) is used when tilting the disc table upward. It can be set to limit the table tilt to about minus 15°. To tilt the table to the full minus 25°, remove the rear stop screw and nut.

Miter Gauge

Refer to Figure 27.

Check the zero setting of the miter gauge. (Note: Make sure the miter slot is parallel to the disc surface.)

1. Place the miter gauge into the disc table slot and loosen the miter gauge knob.
2. Place a square against miter gauge and disc so that it sits flush against both surfaces.
3. Tighten the knob, and check the zero setting. If necessary, adjust the pointer to the zero mark.

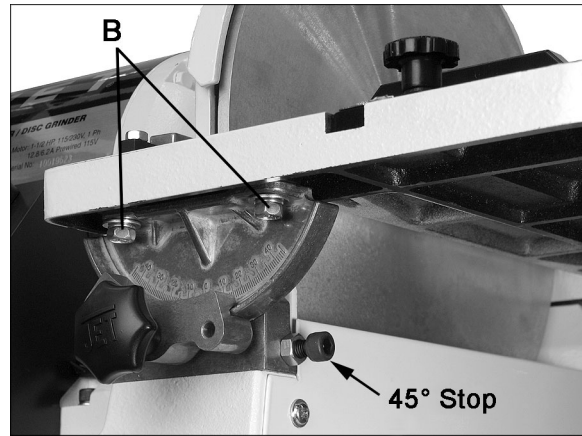

Figure 25

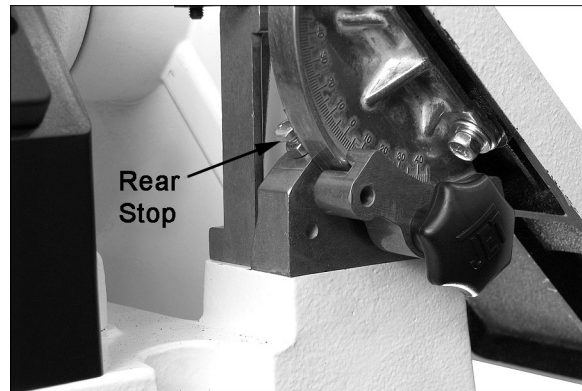

Figure 26

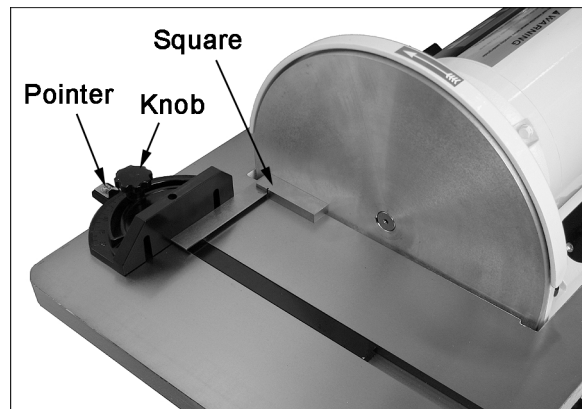

Figure 27

Belt Tracking Adjustment

The belt should run at the center of the belt arm without veering to the left or right. Check this as follows:

1. Disconnect machine from the power source.
2. Rotate the belt by hand and observe how it tracks. The belt should run centered on the belt wheels.
3. If the belt has a tendency to track left or right of center, loosen locking nuts (A, Figure 28).
4. Turn the front screw (B, Figure 28) while turning the belt by hand and observe belt tracking. Once the belt starts to move in the desired direction, stop and turn the rear screw (C) in the same manner. *NOTE: These adjustments are sensitive and should be done in small increments.*
5. Grasp the tensioning adjustment handle (D) and start the machine. Be ready to pull down on the tension adjustment handle should the belt want to run off the belt wheel.
6. Fine adjustment of the tracking may be necessary. When the tracking has stabilized, slowly release the belt tensioning arm and let the machine run for two minutes.
7. Tighten lock nuts (A) when tracking adjustments are satisfactory.

Belt Replacement

1. Disconnect machine from the power source.
2. Remove the lock knob and open the left side panel.
3. Release belt tension using the handle (D, Figure 28), and slide belt off the wheels.
4. Refer to "Installing Abrasives" section for instructions on installing the new belt.

Abrasive Disc Replacement

1. Disconnect machine from the power source.
2. Slowly work the tip of a knife under the abrasive disc, and work it around the circumference of the disc until abrasive can be removed by hand.
3. Clean the aluminum disc of any residual adhesive, using mineral spirits or similar solvent. Allow to dry.
4. See "Installing Abrasives" for instructions on installing the new abrasive disc.

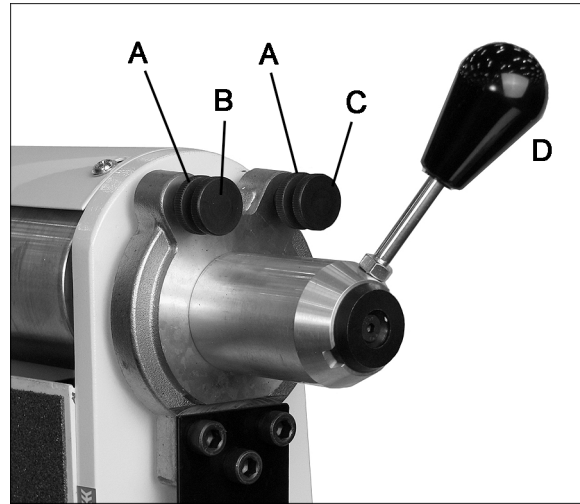

Figure 28

Maintenance

⚠WARNING Before doing maintenance on the machine, disconnect it from the electrical supply by pulling out the plug or switching off the main switch! Failure to comply may cause serious injury.

Wipe the machine down after each use.

Keep exposed metal surfaces clean and rust-free. A light coat of paste wax applied to the tables will help protect the surfaces.

Make periodic inspections of the sander, checking fastener tightness, abrasive wear, tracking accuracy, etc. Listen for any unusual motor noises or vibrations that might indicate bearing fatigue.

(Note: All rotating parts run on sealed ball bearings and do not require lubrication.)

If you will not be using the machine for an extended period, remove the abrasive belt; this will prevent it from stretching and will prolong its life.

If the power cord is worn, cut, or damaged in any way, have it replaced immediately.

Troubleshooting

Trouble	Probable Cause	Remedy
Sander will not start.	Sander unplugged from wall, or motor.	Check all plug connections.
	Fuse blown or circuit breaker tripped.	Replace fuse, or reset circuit breaker. Verify that supply circuit is appropriate for amperage rating on motor plate.
	Cord damaged.	Replace cord.
	Starting capacitor bad.	Replace starting capacitor.
Sanding belt does not come up to speed.	Extension cord too light or too long.	Replace with adequate size and length cord.
	Low current.	Contact a qualified electrician.
Sander vibrates excessively.	Stand on uneven surface.	Adjust stand so that it rests evenly on the floor.
	Bearing fatigue.	Have bearings replaced by a qualified service technician.
	Motor problem.	Have motor inspected by a qualified technician.
Abrasive belt keeps tearing.	Belt running in wrong direction.	Arrows on abrasive belt and machine should be pointing same direction.
Sanded edge not square.	Table not square to abrasive belt.	Use a square to adjust table to abrasive belt.
	Miter slot not parallel to abrasive belt.	Use a square to adjust table's miter slot parallel to abrasive belt.
Sanding marks on wood.	Work held still.	Keep workpiece moving.
	Wrong grit sanding belt.	Use coarser grit for stock removal and fine grit for finish sanding.
	Feed pressure too great.	Never force work into sanding platen.
	Sanding against the grain.	Sand with the grain.

Optional Accessories

708566JSG-6SA, Open Stand

708598JSG-6DC-CS, Closed Stand

Dust Collectors and Accessories.....see your JET distributor

Replacement Parts

Replacement parts are listed on the following pages. To order parts or reach our service department, call 1-800-274-6848 Monday through Friday, 8:00 a.m. to 5:00 p.m. CST. Having the Model Number and Serial Number of your machine available when you call will allow us to serve you quickly and accurately.

Non-proprietary parts, such as fasteners, can be found at local hardware stores, or may be ordered from JET. Some parts are shown for reference only, and may not be available individually.

JSG-6DC Belt/Disc Sander Assembly

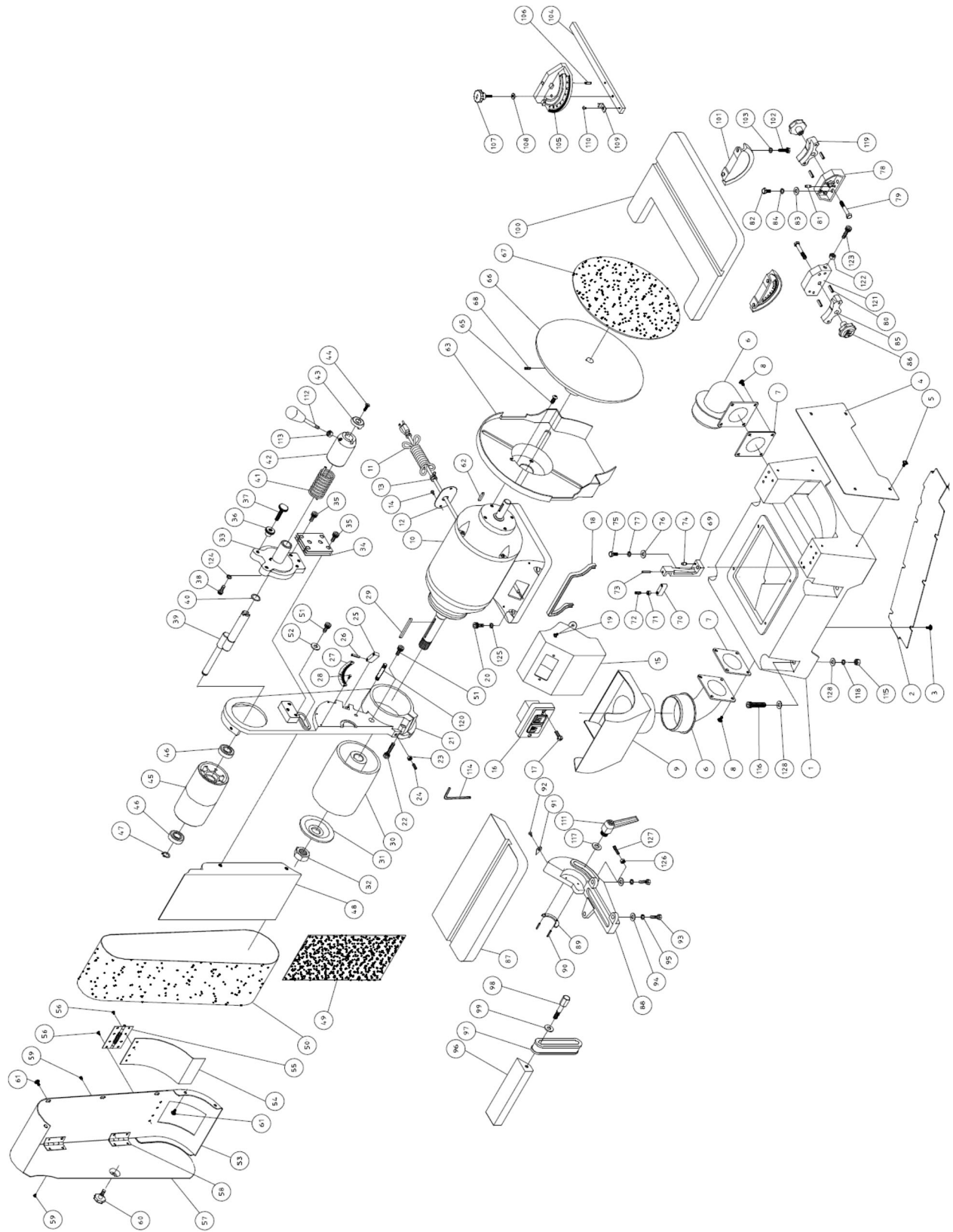

Parts List for JSG-6DC Belt/Disc Sander Assembly

Index No.	Part No.	Description	Size	Qty
1	612001W	Base		1
2	612002W	Base Plate		1
3	SF069300	Pan Head Screw (w/flange)	M6x12	6
4	612003W	Front Plate		1
5	SF069300	Pan Head Screw (w/flange)	M6x12	4
6	612004W	Dust Tube		2
7	612005	Gasket		2
8	SF069300	Pan Head Screw (w/flange)	M6x12	8
9	612006W	Dust Hood		1
10	MA150001W	Motor		1
	990019	Centrifugal Switch		1
	991500	Start Capacitor	500MFD, 125VAC	1
	991050	Run Capacitor	50MFD, 250VAC	1
11	CC324101	Power Cord		1
12	150508	Strain Relief Plate		1
13	998623	Strain Relief		1
14	SF059100	Pan Head Screw (w/flange)	M5x6	2
15	612007	Switch Box		1
16	994503	Switch		1
17	ST040400	Tapping Screw	M4x20	2
18	612008	Pad		1
19	SF059100	Pan Head Screw (w/flange)	M5x12	2
20	SR080700	Hex Socket Cap Screw	M8x35	4
21	612009W	Bracket		1
22	SR080700	Hex Socket Cap Screw	M8x35	1
23	NH061000	Nut	M6	1
24	SS060600	Set Screw	M6x30	1
25	610010	Stop Block		1
26	PS054500	Spring Pin	5x45 mm	1
27	612011	Scale		1
28	VS020500	Rivet	M2x5	3
29	KD050560	Key	5x5x60 mm	1
30	612012	Drive Roller		1
31	612013	Flange		1
32	NH243600	Nut	M24	1
33	612014	Eccentric Shaft Bracket		1
34	612015	Spring Plate		3
35	SR109400	Hex Socket Cap Screw	M10x16	6
36	612016	Nut		2
37	612017	Adjusting Screw		2
38	SR069200	Hex Socket Cap Screw	M6x8	1
39	612018	Eccentric Shaft		1
40	RS200000	Retaining Ring	S20	1
41	612019	Spring		1
42	612020	Eccentric Shaft Bushing		1
43	612021	Locating Block		1
44	SM0606400	Countersunk Head Bolt	M6x20	1
45	612022	Follow Roller		1
46	BB-6202LLU	Ball Bearing	6202LLU	2
47	RS150000	Retaining Ring		1
48	612023W	Sanding Platen		1
49	612024	Sanding Belt Pad		1
50		Sanding Belt (local purchase)		1
51	SR100700	Hex Socket Cap Screw	M10x35	2
52	WF102830	Flat Washer	M10	1
53	612026W	Sanding Belt Guard		1
54	612027W	Outlet Guard		1
55	612028	Hinge		1
56	TS049200	Tapping Screw	M4x8	8
57	612029W	Access Door		1

Index No.	Part No.	Description	Size	Qty
58	612030	Hinge		2
59	ST049200	Tapping Screw	M4x8	8
60	612031	Lock Knob		1
61	SF069300	Pan Head Screw (w/flange)	M6x12	6
62	KD050525	Key	5x5x25 mm	1
63	612032W	Disc Guard		1
65	SP080400	Pan Head Screw	M8x20	4
66	612033	Sanding Disc		1
67		Disc Abrasive (local purchase)		1
68	SS060200	Set Screw	M6x10	2
69	612035	Table Bracket		1
70	612010	Stop Block		1
71	NH061000	Nut	M6	1
72	SS060500	Set Screw	M6x25	1
73	PS052500	Spring Pin	5x25 mm	1
74	150031	Pin		1
75	SH080500	Hex Cap Bolt	M8x25	1
76	WF081818	Flat Washer	M8	1
77	WS080000	Lock Washer	M8	1
78	612037	Table Bracket		1
79	SH080800	Hex Cap Bolt	M8x40	2
80	PS063000	Spring Pin	6x30 mm	4
81	150031	Pin		2
82	SH089400	Hex Cap Bolt	M8x16	4
83	WF081818	Flat Washer	M8	4
84	WS080000	Lock Washer	M8x	4
85	612038	Trunnion Bracket		1
86	990551	Knob		2
87	612039W	Sanding Table		1
88	612040W	Trunnion		1
89	612041	Sliding Plate		1
90	PS040800	Spring Pin	4x12 mm	2
91	612056	Pointer		1
92	SF059100	Pan Head Screw (w/flange)	M5x6	1
93	SH080400	Hex Cap Bolt	M8x20	3
94	WF081818	Flat Washer	M8	3
95	WS080000	Lock Washer	M8	3
	AA612042	Workstop Assembly CP		1
96	612042W	Fence		1
97	612043W	Support Arm		1
98	612044	Stud		1
99	WF102825	Flat Washer	M10	1
100	612045W	Table		1
101	612046	Trunnion		2
102	SH089400	Hex Cap Bolt	M8x16	4
103	WS080000	Lock Washer	M8	4
	AA150401	Miter Gauger Assembly CP		1
104	150401	Guide Bar		1
105	199083	Gauge Body		1
106	PS051200	Spring Pin	5x12 mm	1
107	612036	Knob		1
108	150406	Gasket		1
109	150402	Pointer		1
110	SP550200	Pan Head Screw	3/16" x 1/4"	1
111	612047	Lock Knob Assembly		1
112	612048	Handle		1
113	NH081300	Nut	M8	1
114	TS-1527071	Hex Wrench	6mm	1
115	NH101700	Nut *	M10	4
116	SR1016003	Socket Head Cap Bolt *	M10x80	4
117	WF102825	Flat Washer	M10	9
118	WS100000	Lock Washer *	M10	4

Index No.	Part No.	Description	Size	Qty
119	612052	Trunnion Holder		1
120	612053	Stud		1
121	612054	Table Bracket		1
122	NH081300	Nut	M8	1
123	SR080500	Hex Socket Cap Screw	M8x25	1
124	WS060000	Lock Washer	M6	1
125	WS080000	Lock Washer	M8	4
126	NH061000	Nut	M6	2
127	SS060600	Set Screw	M6x30	2
128	WF102030	Flat Washer	M6x30	8

* Items included in AH612J1 Hardware Kit

Closed Stand Assembly (Optional)

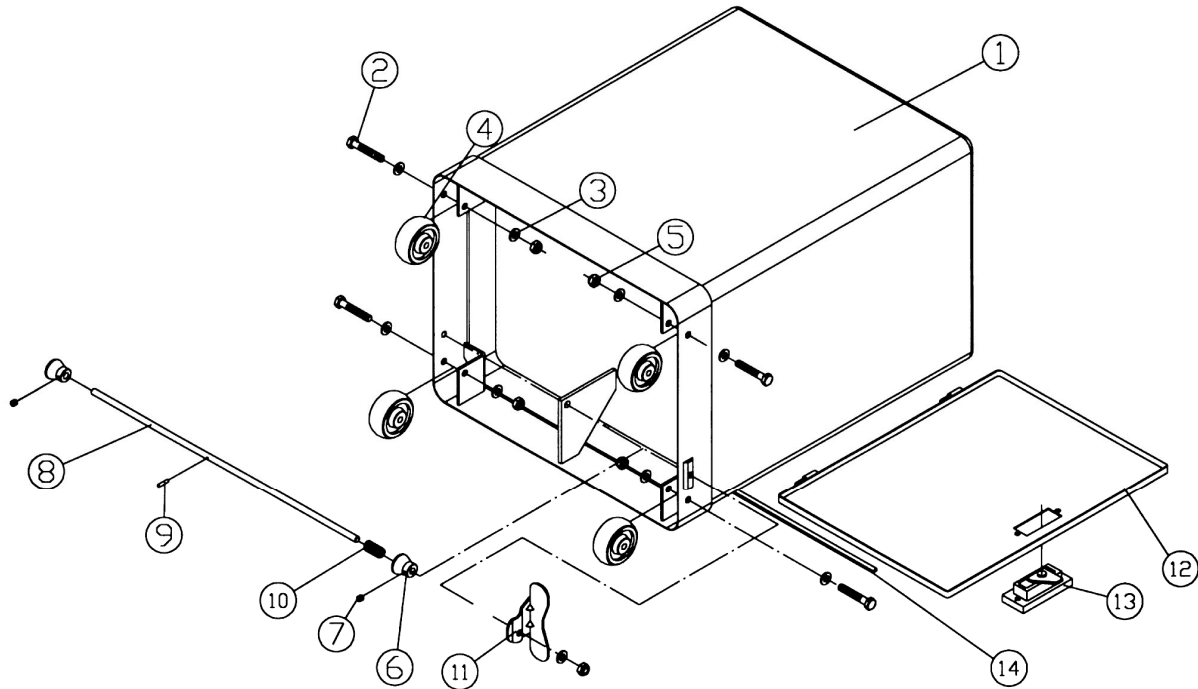

Index No.	Part No.	Description	Size	Qty
	708598	Closed Stand Assembly Complete		1
1	AB612062	Closed Stand		1
2	TS-0060111	Hex Cap Screw	3/8" x 2-1/2"	4
3	TS-1550071	Flat Washer	M10 x 20	9
4	150105	Wheel		4
5	TS-0640091	Nyloc Lock Nut	3/8"	5
6	150103	Stop		2
7	TS-1523031	Set Screw	M6 x 10	2
8	612063	Stop Shaft		1
9	PS042400	Spring Pin	4 x 24 mm	1
10	150106	Spring		1
11	150104	Step Plate		1
12	145002	Door		1
13	150503	Lock		1
14	150527	Pad		2

Hardware used to attach the Sander to the Closed Stand

.....	AH612J1	Hardware Bag (contains the items below)		1
.....	TS-229801	Hex Cap Screw (not shown)	M10 x 1.5 x 80	4
.....	TS-1550071	Flat Washer (not shown)	M10	8
.....	TS-1551071	Lock Washer (not shown)	M10	4
.....	TS-1540077	Hex Nut (not shown)	M10 x 1.5	4

Open Stand Assembly (Optional)

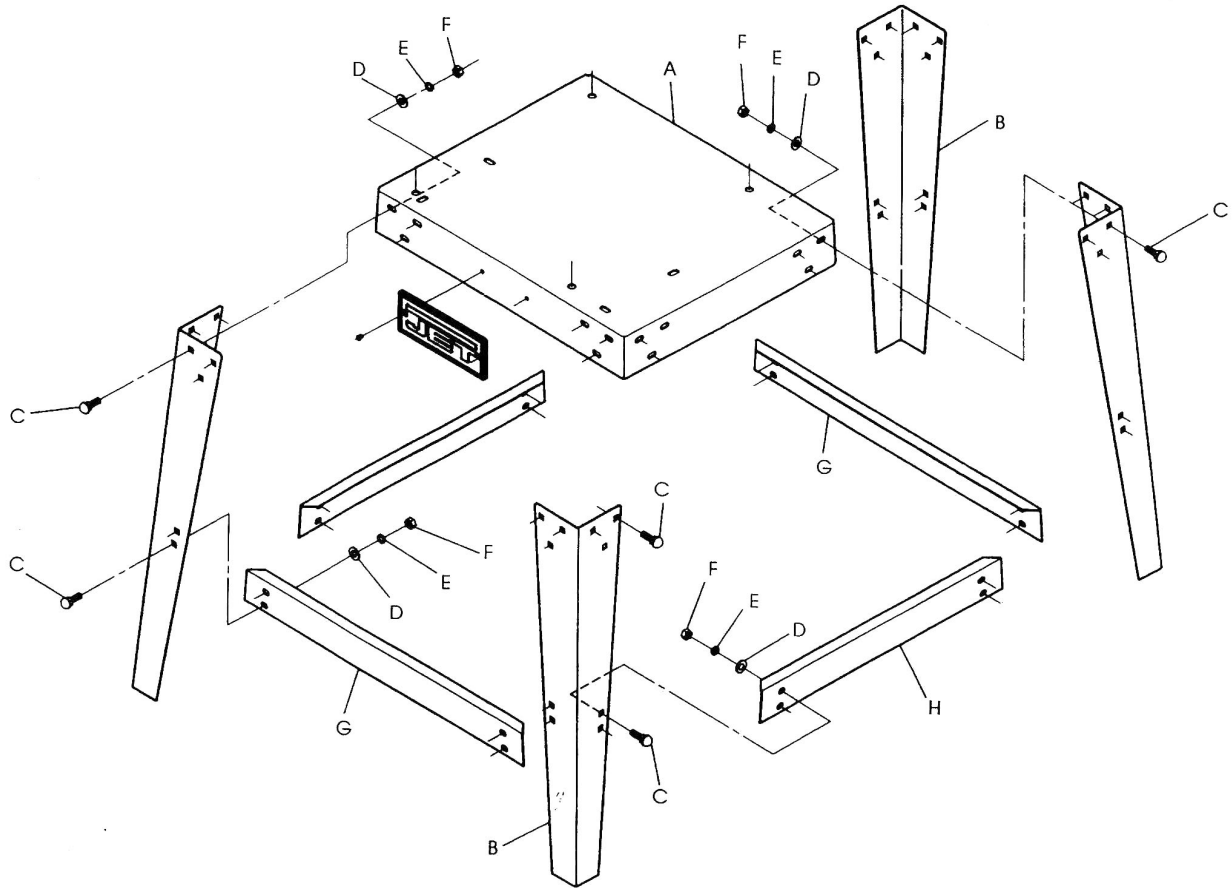

Parts List for Open Stand Assembly (Optional)

Index No.	Part No.	Description	Size	Qty
	708566	Open Stand Assembly Complete		1
A	612049	Stand Top (blue)		1
	612049W	Stand Top (white)		1
B	150603	Stand Leg (blue)		4
	150603W	Stand Leg (white)		4
C	SC089400	Carriage Bolt *	M8 x 16	40
D	WF081818	Flat Washer *	M8	40
E	WS080000	Lock Washer *	M8	40
F	NH081300	Hex Nut *	M8	40
G	612051	Cross Brace – short (blue)		2
	612501W	Cross Brace – short (white)		2
H	612050	Cross Brace – long (blue)		2
	612050W	Cross Brace – long (white)		2
	AB612101	Hardware Bag (includes items marked with *)		1

Electrical Connections

230V

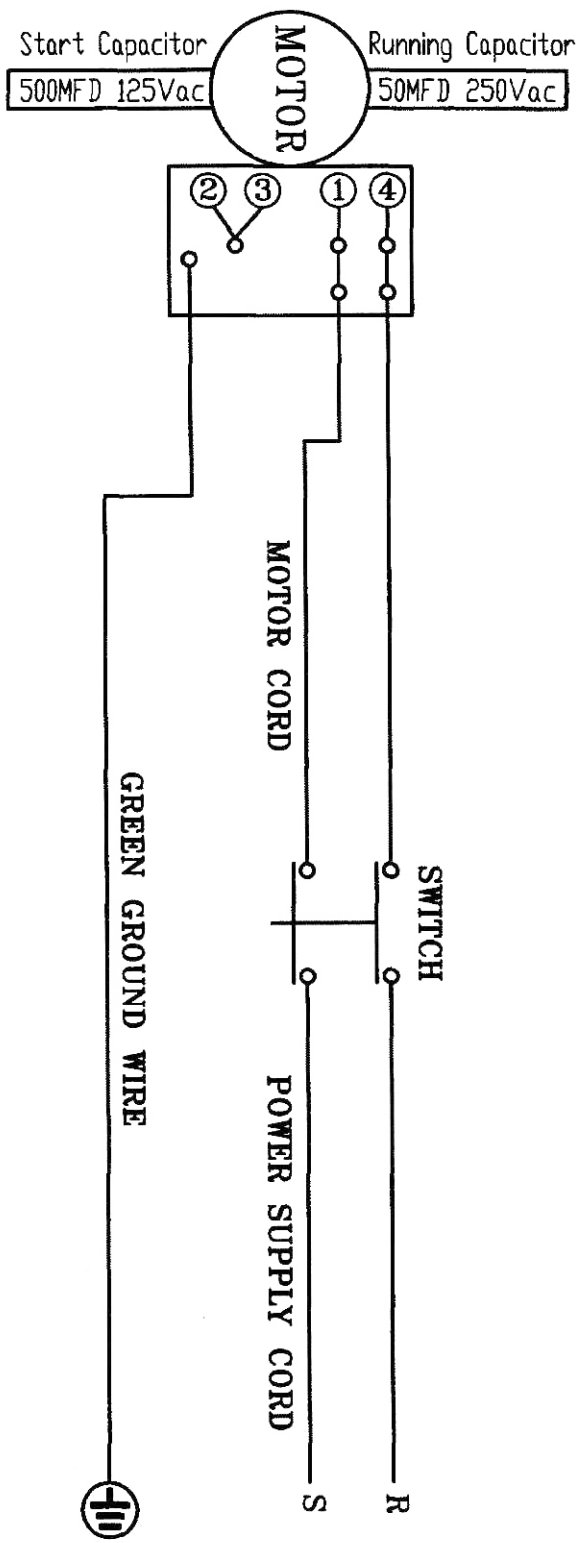

115V

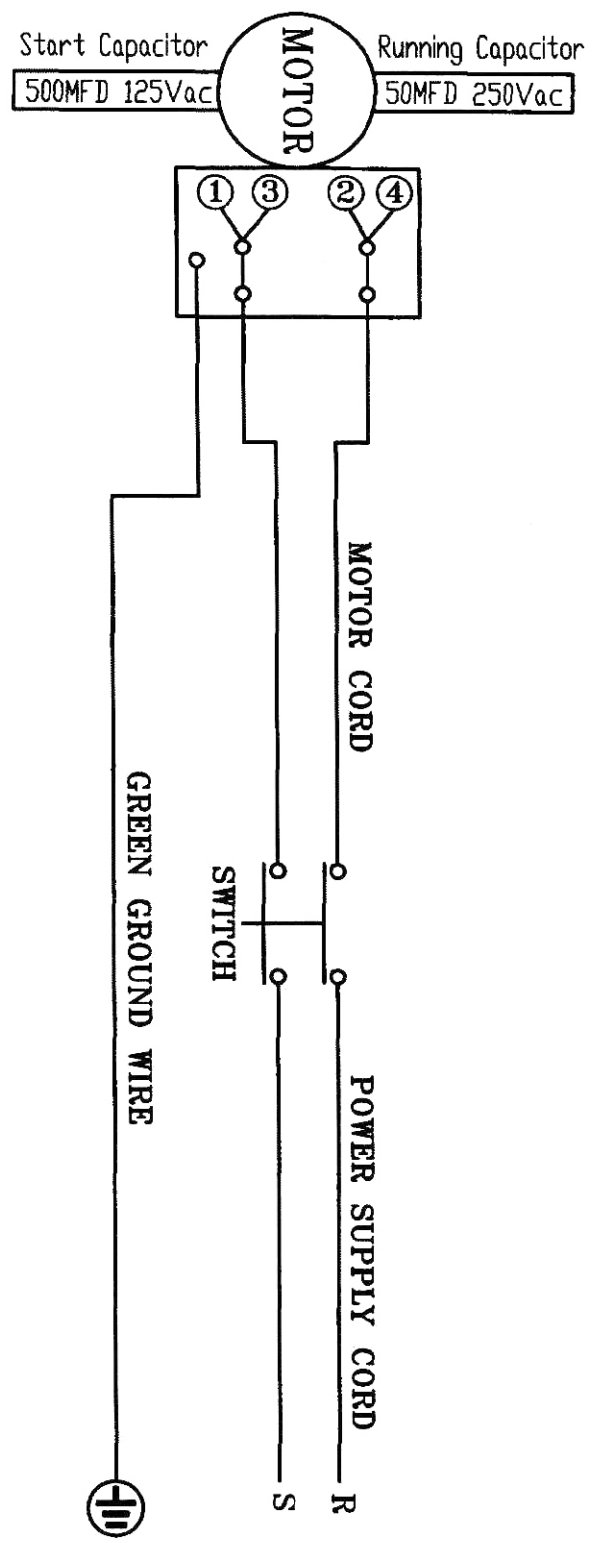



427 New Sanford Road
LaVergne, Tennessee 37086
Phone: 800-274-6848
www.jettools.com